

Solicitation Response(SR) Dept: 0310 ID: ESR0309200000005151 Ver.: 1 Function: New Phase: Final

Modified by batch , 03/19/2020

Header  4

General Information Contact Default Values Discount Document Information

Procurement Folder:

689178

Procurement Type:

Agency Master Agreement

Vendor ID:

000000160430

Legal Name:

STUCK ENTERPRISES INC

Alias/DBA:**Total Bid:**

\$7,900.00

Response Date:

03/09/2020

Response Time:

17:11

SO Doc Code:

ARFQ

SO Dept:

0310

SO Doc ID:

DNR2000000032

Published Date:

3/13/20

Close Date:

3/19/20

Close Time:

13:30

Status:

Closed

Solicitation Description:

Addendum No 04_Open-End

Propane Contract - Cacapon

Total of Header Attachments:

4

Total of All Attachments:

4

Amended Total Bid:

\$530,350.00

Vendor Mark Up: \$0.72



**State of West Virginia
Request For
Quotation**

Procurement Folder :689178

Document Description : Open-End Propane Contract for Cacapon Resort State Park

Procurement Type :Agency Master Agreement

Date Issued	Solicitation Closes	Solicitation No	Version	Phase
2020-02-14	2020-03-10 13:30:00	ARFQ 0310 DNR2000000032	1	Final

SUBMIT RESPONSES TO:	VENDOR
BID RESPONSE DIVISION OF NATURAL RESOURCES PROPERTY & PROCUREMENT OFFICE 324 4TH AVE SOUTH CHARLESTON WV 25303-1228 US	Vendor Name, Address and Telephone Stuck Enterprises 1115 East High Street Waynesburg, PA 724-627-3757

FOR INFORMATION CONTACT THE

James H Adkins
 (304) 558-3397
 jamie.h.adkins@wv.gov

Signature X *JoJo Lambiotte*

FEIN # 251305625

DATE 3-4-20

All offers subject to all terms and conditions contained in this solicitation

INVOICE TO		SHIP TO	
SUPERINTENDENT DIVISION OF NATURAL RESOURCES CACAPON RESORT STATE PARK 818 CACAPON LODGE DR BERKELEY SPRINGS WV25411-3300 US		SUPERINTENDENT DIVISION OF NATURAL RESOURCES CACAPON RESORT STATE PARK 818 CACAPON LODGE DR BERKELEY SPRINGS WV 25411 US	

Line	Commodity Line Description	Qty	Unit Issue	Unit Price	Total Price
1	Propane				

Commodity Code	Manufacturer	Model #	Specification
15111501			

Extended Description
Please see Exhibit A - Pricing Page

SCHEDULE OF EVENTS

<u>Line</u>	<u>Event</u>	<u>Event Date</u>
1	Non-Mandadory Pre-Bid Meeting @ 10 a.m. EST	2020-02-20
2	Technical Question Deadline at 9:00 a.m. EST	2020-02-27

DNR2000000032	Document Phase Final	Document Description Open-End Contract for Propane at Cacapon Resort State Park	Page 3 of 3
---------------	--------------------------------	--	------------------------------

ADDITIONAL TERMS AND CONDITIONS

See attached document(s) for additional Terms and Conditions



West Virginia Division of Natural Resources

INSTRUCTIONS TO VENDORS
&
AGENCY TERMS AND CONDITIONS

INSTRUCTIONS

1. REVIEW DOCUMENTS THOROUGHLY: The attached documents contain a solicitation for bids. Please read these instructions and all documents attached in their entirety. These instructions provide critical information about requirements that if overlooked could lead to disqualification of a Vendor's bid. All bids must be submitted in accordance with the provisions contained in these instructions and the Solicitation. Failure to do so may result in disqualification of a Vendor's bid.

2. MANDATORY TERMS: The Solicitation may contain mandatory provisions identified by the use of the words "must," "will," and "shall" which identify a mandatory item or requirement. Failure to comply with a mandatory term in the Solicitation will result in bid disqualification.

3. PREBID MEETING: The item identified below shall apply to this Solicitation.

A pre-bid meeting will not be held prior to bid opening.

A **NON-MANDATORY** pre-bid meeting will be held at the following place and time:

Cacapon Resort State Park Headquarters
818 Cacapon Lodge Drive
Berkeley Springs WV 25411

Thursday, FEBRUARY 20, 2020 at 10:00 a.m. EST

A **MANDATORY** pre-bid meeting will be held at the following place and time:

All Vendors submitting a bid must attend the mandatory pre-bid meeting. Failure to attend the mandatory pre-bid meeting shall result in disqualification of the Vendor's bid. No one person attending the pre-bid meeting may represent more than one Vendor.

An attendance sheet provided at the pre-bid meeting shall serve as the official document verifying attendance. The State will not accept any other form of proof or documentation to verify attendance. Any person attending the pre-bid meeting on behalf of a Vendor must list on the attendance sheet his or her name and the name of the Vendor he or she is representing.

Additionally, the person attending the pre-bid meeting should include the Vendor's e-mail address, phone number, and Fax number on the attendance sheet. It is the Vendor's responsibility to locate the attendance sheet and provide the required information. Failure to complete the attendance sheet as required may result in disqualification of Vendor's bid.

All Vendors should arrive prior to the starting time for the pre-bid. Vendors who arrive after the starting time but prior to the end of the pre-bid will be permitted to sign in, but are charged with knowing all matters discussed at the pre-bid.

Questions submitted at least five (5) business days prior to a scheduled pre-bid will be discussed at the pre-bid meeting if possible. Any discussions or answers to questions at the pre-bid meeting are preliminary in nature and are non-binding. Official and binding answers to questions will be published in a written addendum to the Solicitation prior to bid opening.

4 VENDOR QUESTION DEADLINE: Vendors may submit questions relating to this Solicitation to the Property and Procurement Office. Questions must be submitted in writing. All questions must be submitted on or before the date listed below and to the address listed below in order to be considered. A written response will be published in a Solicitation addendum if a response is possible and appropriate. Non-written discussions, conversations, or questions and answers regarding this Solicitation are preliminary in nature and are nonbinding.

Submitted e-mails should have solicitation number in the subject line.

Question Submission Deadline: Thursday, FEBRUARY 27, 2020 @ 9:00 a.m. EST

Submit Questions to: West Virginia Division of Natural Resources
Property and Procurement Office
Attention: Mr. Jamie Adkins
South Charleston, WV 25303
Fax: (304) 558-2165
Email: Jamie.H.Adkins@wv.gov

5. VERBAL COMMUNICATION: Any verbal communication between the Vendor and any State personnel is not binding, including verbal communication at the mandatory pre-bid conference. Only information issued in writing and added to the Solicitation by an official written addendum by the Property and Procurement Office is binding.

6. BID SUBMISSION: All bids must be submitted electronically through wvOASIS or signed and delivered by the Vendor to the Property and Procurement Office at the address listed below on or before the date and time of the bid opening. Any bid received by the Property and Procurement Office is considered to be in the possession of the Office and will not be returned for any reason. Acceptable delivery methods include electronic submission via wvOASIS, hand delivery, delivery by courier, or facsimile.

The bid delivery address is:

West Virginia Division of Natural Resources
Property and Procurement Office
324 4th Avenue
South Charleston, WV 25303

A bid that is not submitted electronically through wvOASIS should contain the information listed below on the face of the envelope or the bid may be rejected by the West Virginia Division of Natural Resources.:

SEALED BID:

BUYER: Mr. Jamie Adkins

SOLICITATION NUMBER: ARFQ DNR20*32

BID CLOSING DATE: Tuesday, MARCH 10, 2020

BID CLOSING TIME: 1:30 p.m. EST

FAX NUMBER: 304-558-2165

The Property and Procurement Office may prohibit the submission of bids electronically through wvOASIS at its sole discretion. Such a prohibition will be contained and communicated in the wvOASIS system resulting in the Vendor's inability to submit bids through wvOASIS. Submission of a response to an Expression of Interest or Request for Proposal is not permitted in wvOASIS.

For Agency Request for Proposal ("ARFP") Responses Only: In the event that Vendor is responding to a request for proposal, the Vendor shall submit one original technical and one original cost proposal plus convenience copies of each to the Property and Procurement Office at the address shown above. Additionally, the Vendor should identify the bid type as either a technical or cost proposal on the face of each bid envelope submitted in response to a request for proposal as follows:

BID TYPE:

Technical

Cost

7. BID OPENING: Bids submitted in response to this Solicitation will be opened at the location identified below on the date and time listed below. Delivery of a bid after the bid opening date and time will result in bid disqualification. For purposes of this Solicitation, a bid is considered delivered when confirmation of delivery is provided by wvOASIS (in the case of electronic submission) or when the bid is time stamped by the official Property and Procurement Office time clock (in the case of hand delivery).

Bid Opening Time and Date: 1:30 p.m. EST on Tuesday, MARCH 10, 2020

Bid Opening Location:
West Virginia Division of Natural Resources
Property and Procurement Office
324 4th Avenue
South Charleston, WV 25303

8. ADDENDUM ACKNOWLEDGEMENT: Changes or revisions to this Solicitation will be made by an official written addendum issued by the Property and Procurement Office. Vendor should acknowledge receipt of all addenda issued with this Solicitation by completing an Addendum Acknowledgment Form, a copy of which is included herewith. Failure to acknowledge addenda may result in bid disqualification. The addendum acknowledgement should be submitted with the bid to expedite document processing.

9. BID FORMATTING: Vendor should type or electronically enter the information onto its bid to prevent errors in the evaluation. Failure to type or electronically enter the information may result in bid disqualification.

10. ALTERNATE MODEL OR BRAND: Unless the box below is checked, any model, brand, or specification listed in this Solicitation establishes the acceptable level of quality only and is not intended to reflect a preference for, or in any way favor, a particular brand or vendor. Vendors may bid alternates to a listed model or brand provided that the alternate is at least equal to the model or brand and complies with the required specifications. The equality of any alternate being bid shall be determined by the State at its sole discretion. Any Vendor bidding an alternate model or brand should clearly identify the alternate items in its bid and should include manufacturer's specifications, industry literature, and/or any other relevant documentation demonstrating the equality of the alternate items. Failure to provide information for alternate items may be grounds for rejection of a Vendor's bid.

This solicitation is based upon a standardized commodity established under W. Va. Code §5A-3-61. Vendors are expected to bid the standardized commodity identified. Failure to bid the standardized commodity will result in your firm's bid being rejected.

11. EXCEPTIONS AND CLARIFICATIONS: The Solicitation contains the specifications that shall form the basis of a contractual agreement. Vendor shall clearly mark any exceptions, clarifications, or other proposed modifications in its bid. Exceptions to, clarifications of, or

modifications of a requirement or term and condition of the Solicitation may result in bid disqualification.

12. COMMUNICATION LIMITATIONS: In accordance with West Virginia Division of Natural Resources Series IV Purchasing Guidelines and Procedures §6.6, communication with the State of West Virginia or any of its employees regarding this Solicitation during the solicitation, bid, evaluation or award periods, except through the Property and Procurement Office, is strictly prohibited without prior Property and Procurement Office approval. Property and Procurement Office approval for such communication is implied for all agency delegated and exempt purchases.

13. REGISTRATION: Prior to Contract award, the apparent successful Vendor must be properly registered with the West Virginia Purchasing Division and must have paid the \$125 fee, if applicable.

14. UNIT PRICE: Unit prices shall prevail in cases of a discrepancy in the Vendor's bid.

15. PREFERENCE: Vendor Preference may be requested in purchases of motor vehicles or construction and maintenance equipment and machinery used in highway and other infrastructure projects. Any request for preference must be submitted in writing with the bid, must specifically identify the preference requested with reference to the applicable subsection of West Virginia Code §5A-3-37, and should include with the bid any information necessary to evaluate and confirm the applicability of the requested preference. A request form to help facilitate the request can be found at: <http://www.state.wv.us/admin/purchase/vrc/Venpref.pdf>.

15A. RECIPROCAL PREFERENCE: The State of West Virginia applies a reciprocal preference to all solicitations for commodities and printing in accordance with the W. Va. Code §5A-3-37(b). In effect, non-resident vendors receiving a preference in their home states will see that same preference granted to West Virginia resident vendors bidding against them in West Virginia. A request form to help facilitate the request can be found at : <http://www.state.wv.us/admin/purchase/vrc/Venpref/pdf>.

16. SMALL, WOMEN-OWNED, OR MINORITY-OWNED BUSINESSES: For any solicitations publicly advertised for bid, in accordance with W. Va. Code §5A-3-37(a)(7) and W. Va. Code R. § 148-22-9, any non-resident vendor certified as a small, women-owned, or minority owned business under W. Va. Code R. § 148-22-9 shall be provided the same preference made available to any resident vendor. Any non-resident small, women-owned, or minority-owned business must identify itself as such in writing, must submit that writing to the Property and Procurement Office with its bid, and must be properly certified under W. Va. Code R. § 148-22-9 prior to contract award to receive the preferences made available to resident vendors. Preference for a non-resident small, women-owned, or minority owned business shall be applied in accordance with W. Va. Code R. § 148-22-9.

17. WAIVER OF MINOR IRREGULARITIES: The Chief Procurement Officer reserves the right to waive minor irregularities in bids or specifications in accordance with West Virginia Division of Natural Resources Series IV Purchasing Guidelines and Procedures § 4.1.g.

18. ELECTRONIC FILE ACCESS RESTRICTIONS: Vendor must ensure that its submission in wvOASIS can be accessed and viewed by the Property and Procurement Office staff immediately upon bid opening. The Property and Procurement Office will consider any file that cannot be immediately accessed and viewed at the time of the bid opening (such as, encrypted files, password protected files, or incompatible files) to be blank or incomplete as context requires and are therefore unacceptable. A vendor will not be permitted to unencrypt files, remove password protections, or resubmit documents after bid opening to make a file viewable if those documents are required with the bid. A Vendor may be required to provide document passwords or remove access restrictions to allow the Property and Procurement Office to print or electronically save documents provided that those documents are viewable by the Property and Procurement Office prior to obtaining the password or removing the access restriction.

19. NON-RESPONSIBLE: The Chief Procurement Officer reserves the right to reject the bid of any vendor as Non-Responsible in accordance with West Virginia Division of Natural Resources Series IV Purchasing Guidelines and Procedures §5.5.a., when the Chief Procurement Officer determines that the vendor submitting the bid does not have the capability to fully perform, or lacks the integrity and reliability to assure good-faith performance.

20. ACCEPTANCE/REJECTION: The Agency may accept or reject any bid in whole, or in part in accordance with West Virginia Division of Natural Resources Series IV Purchasing Guidelines and Procedures §4.1. f. and §6.4. b.

21. YOUR SUBMISSION IS A PUBLIC DOCUMENT: Vendor's entire response to the Solicitation and the resulting Contract are public documents. As public documents, they will be disclosed to the public following the bid/proposal opening or award of the contract, as required by the competitive bidding laws of W. Va. Code §§ 5A-3-1 et seq., 5-22-1 et seq., and 5G-1-1 et seq. and the Freedom of Information Act W. Va. Code §§ 29B-1-1 et seq.

DO NOT SUBMIT MATERIAL YOU CONSIDER TO BE CONFIDENTIAL, A TRADE SECRET(S), OR OTHERWISE NOT SUBJECT TO PUBLIC DISCLOSURE.

Submission of any bid, proposal, or other document to the Property and Procurement Office constitutes your explicit consent to the subsequent public disclosure of the bid, proposal, or document. The Property and Procurement Office will disclose any document labeled "confidential," "proprietary," "trade secret," "private," or labeled with any other claim against public disclosure of the documents, to include any "trade secrets" as defined by W. Va. Code § 47-22-1 et seq. All submissions are subject to public disclosure without notice.

22. INTERESTED PARTY DISCLOSURE: West Virginia Code § 6D-1-2 requires that the vendor submit to the Purchasing Division a disclosure of interested parties to the contract for all contracts with an actual or estimated value of at least \$1 Million. That disclosure must occur on the form prescribed and approved by the WV Ethics Commission prior to contract award. A copy of that form is included with this solicitation or can be obtained from the WV Ethics Commission. This requirement does not apply to publicly traded companies listed on a national or international stock exchange. A more detailed definition of interested parties can be obtained from the form referenced above.

23. WITH THE BID REQUIREMENTS: In instances where these specifications require documentation or other information with the bid, and a vendor fails to provide it with the bid, the Director of the Purchasing Division reserves the right to request those items after bid opening and prior to contract award pursuant to the authority to waive minor irregularities in bids or specifications under W. Va. CSR § 148-1-4.6. This authority does not apply to instances where state law mandates receipt with the bid.

AGENCY TERMS & CONDITIONS

1. CONTRACTUAL AGREEMENT: Issuance of an Award Document signed by the Chief Procurement Officer, or his or her designee, and approved as to form by the Attorney General's office constitutes acceptance of this Contract made by and between the State of West Virginia and the Vendor. Vendor's signature on its bid signifies Vendor's agreement to be bound by and accept the terms and conditions contained in this Contract.

2. DEFINITIONS: As used in this Solicitation/Contract, the following terms shall have the meanings attributed to them below. Additional definitions may be found in the specifications included with this Solicitation/Contract.

- a. **"Agency"** means the West Virginia Division of Natural Resources.
- b. **"Bid" or "Proposal"** means a vendor's submitted response to a solicitation.
- c. **"Contract"** means the binding agreement that is entered into between the State and the Vendor to provide the goods or services requested in the Solicitation.
- d. **"Chief Procurement Officer"** means the Chief Procurement Officer of the West Virginia Division of Natural Resources or anyone that the Chief Procurement Officer has designated to perform a specific task or function.
- e. **"Property and Procurement Office"** means the unit within the West Virginia Division of Natural Resources' Administration Section headed by the Chief Procurement Officer and its personnel.
- f. **"Director of the Purchasing Division"** means the Director of the West Virginia Department of Administration, Purchasing Division.
- g. **"Award Document"** means the document signed by the Agency and the Property and Procurement Office and approved as to form by the Attorney General that identifies the Vendor as the contract holder.
- h. **"Solicitation"** means the official notice of an opportunity to supply the State with goods or services that is published by the Property and Procurement Office.
- i. **"State"** means the State of West Virginia and/or any of its agencies, commissions, boards, etc. as context requires.
- j. **"Vendor" or "Vendors"** means any entity submitting a bid in response to the Solicitation, the entity that has been selected as the lowest responsible bidder, or the entity that has been awarded the Contract as context requires.

- k. "Will", "Shall" and "Must" identifies a mandatory item or requirement that is the duty, obligation, or requirement imposed is mandatory as opposed to being directory or permissive.

3 CONTRACT TERM; RENEWAL; EXTENSION: The term of this Contract shall be determined in accordance with the category that has been identified as applicable to this Contract below:

Term Contract

Initial Contract Term: This Contract becomes effective on AWARD and extends for a period of ONE (1) year(s).

Renewal Term: This Contract may be renewed upon the mutual written consent of the Agency, and the Vendor, with approval of the Property and Procurement Office and the Attorney General's office (Attorney General approval is as to form only). Any request for renewal should be submitted to the Property and Procurement Office thirty (30) days prior to the expiration date of the initial contract term or appropriate renewal term. A Contract renewal shall be in accordance with the terms and conditions of the original contract. Renewal of this Contract is limited to THREE (3) successive one (1) year periods or multiple renewal periods of less than one year, provided that the multiple renewal periods do not exceed the total number of month available in all renewal years combined. Automatic renewal of this Contract is prohibited. Notwithstanding the foregoing, Property and Procurement Office approval is not required on Section delegated or exempt purchases. Attorney General approval may be required for vendor terms and conditions.

Alternate Renewal Term – This contract may be renewed for _____ successive _____ year periods or shorter periods provided that they do not exceed the total number of months contained in all available renewals. Automatic renewal of this Contract is prohibited. Renewals must be approved by the Vendor, Agency, Property and Procurement Office and Attorney General's office (Attorney General approval is as to form only)

Delivery Order Limitations: In the event that this contract permits delivery orders, a delivery order may only be issued during the time this Contract is in effect. Any delivery order issued within one year of the expiration of this Contract shall be effective for one (1) year from the date the delivery order is issued. No delivery order may be extended beyond one year after this Contract has expired.

Fixed Period Contract: This Contract becomes effective upon Vendor's receipt of the notice to proceed and must be completed within _____ days.

Fixed Period Contract with Renewals: This Contract becomes effective upon Vendor's receipt of the notice to proceed and part of the Contract more fully described in the attached specifications must be completed within _____ days. Upon completion of the work covered by the preceding sentence, the vendor agrees that maintenance, monitoring, or warranty services will be provided for _____ year(s) thereafter.

One-Time Purchase: The term of this Contract shall run from the issuance of the Award Document until all of the goods contracted for have been delivered, but in no event, will this Contract extend for more than one fiscal year.

Other: See attached.

4. NOTICE TO PROCEED: Vendor shall begin performance of this Contract immediately upon receiving notice to proceed unless otherwise instructed by the Agency. Unless otherwise specified, the fully executed Award Document will be considered notice to proceed.

5. QUANTITIES: The quantities required under this Contract shall be determined in accordance with the category that has been identified as applicable to this Contract below.

Open-End Contract: Quantities listed in this Solicitation are approximations only, based on estimates supplied by the Agency. It is understood and agreed that the Contract shall cover the quantities actually ordered for delivery during the term of the Contract, whether more or less than the quantities shown.

Service: The scope of the service to be provided will be more clearly defined in the specifications included herewith.

Combined Service and Goods: The scope of the service and deliverable goods to be provided will be more clearly defined in the specifications included herewith.

One-Time Purchase: This Contract is for the purchase of a set quantity of goods that are identified in the specifications included herewith. Once those items have been delivered, no additional goods may be procured under this Contract without an appropriate change order approved by the Vendor, Agency, Property and Procurement Office and Attorney General's office.

6. EMERGENCY PURCHASES: The Chief Procurement Officer may authorize the Agency to purchase goods or services in the open market that Vendor would otherwise provide under this Contract if those goods or services are for immediate or expedited delivery in an emergency. Emergencies shall include, but are not limited to, delays in transportation or an unanticipated increase in the volume of work. An emergency purchase in the open market, approved by the Chief Procurement Officer, shall not constitute a breach of this Contract and shall not entitle the Vendor to any form of compensation or damages. This provision does not excuse the State from fulfilling its obligations under a One-Time Purchase contract.

7. REQUIRED DOCUMENTS: All of the items checked below must be provided to the Property and Procurement Office by the Vendor as specified below.

BID BOND (Construction Only): Pursuant to the requirements contained in W. Va. Code § 5-22-1(c), All Vendors submitting a bid on a construction project shall furnish a valid bid bond in the amount of five percent (5%) of the total amount of the bid protecting the State of West Virginia. The bid bond must be submitted with the bid.

PERFORMANCE BOND: The apparent successful Vendor shall provide a performance bond in the amount of 100% of the Contract value. The performance bond must be received by the Property and Procurement Office prior to Contract award.

LABOR/MATERIAL PAYMENT BOND: The apparent successful Vendor shall provide a labor/material payment bond in the amount of 100% of the Contract value. The labor/material payment bond must be delivered to the Property and Procurement Office prior to Contract award.

MAINTENANCE BOND: The apparent successful Vendor shall provide a two (2) year maintenance bond covering the roofing system. The maintenance bond must be issued and delivered to the Property and Procurement Office prior to Contract award.

LICENSE(S) / CERTIFICATIONS / PERMITS: In addition to anything required under the Section entitled Licensing, of the General Terms and Conditions, the apparent successful Vendor shall furnish proof of the following licenses, certifications, and/or permits prior to Contract award, in a form acceptable to the Property and Procurement Office.

WV State Tax Office License as a Refiner, Distributer or Dealer _____

The apparent successful Vendor shall also furnish proof of any additional licenses or certifications contained in the specifications prior to Contract award regardless of whether or not that requirement is listed above.

8. INSURANCE: The apparent successful Vendor shall furnish proof of the insurance identified by a check mark below prior to Contract award. Subsequent to contract award, and prior to the insurance expiration date, Vendor shall provide the Agency with proof that the insurance mandated herein has been continued. Vendor must also provide Agency with immediate notice of any changes in its insurance policies mandated herein, including but not limited to, policy cancellation, policy reduction, or change in insurers. The insurance coverages identified below must be maintained throughout the life of this contract. The apparent successful Vendor shall also furnish proof of any additional insurance requirements contained in the specifications prior to Contract award regardless of whether or not that insurance requirement is listed in this section.

Vendor must maintain:

Commercial General Liability Insurance in at least an amount of:

\$1,000,000 _____

Automobile Liability Insurance in at least an amount of \$500,000 _____

Professional/Malpractice/Errors and Omission Insurance in at least an amount of:

Commercial Crime and Third-Party Fidelity Insurance in an amount of:

Cyber Liability Insurance in an amount of: _____

Builders Risk Insurance in an amount equal to 100% of the amount of the Contract.

Other _____

Notwithstanding anything contained in this section to the contrary, the Chief Procurement Officer reserves the right to waive the requirement that the Agency be named as an additional insured on one or more of the Vendor's insurance policies if the Chief Procurement Officer finds that doing so is in the best interest of the Agency.

9. WORKERS' COMPENSATION INSURANCE: The apparent successful Vendor shall comply with laws relating to workers' compensation, shall maintain workers' compensation insurance when required, and shall furnish proof of workers' compensation insurance upon request.

10. LIQUIDATED DAMAGES: This clause shall in no way be considered exclusive and shall not limit the State or Agency's right to pursue any other available remedy. Vendor shall pay liquidated damages in the amount specified below or as described in the specifications:

_____ **N/A** _____ for _____

Liquidated Damages Contained in the Specifications

11. ACCEPTANCE: Vendor's signature on its bid, or on the certification and signature page, constitutes an offer to the State that cannot be unilaterally withdrawn, signifies that the product or service proposed by vendor meets the mandatory requirements contained in the Solicitation for that product or service, unless otherwise indicated, and signifies acceptance of the terms and conditions contained in the Solicitation unless otherwise indicated.

12. PRICING: The pricing set forth herein is firm for the life of the Contract, unless specified elsewhere within this Solicitation/Contract by the State. A Vendor's inclusion of price adjustment provisions in its bid, without an express authorization from the State in the Solicitation to do so, may result in bid disqualification. Notwithstanding the foregoing, Vendor must extend any publicly advertised sale price to the State and invoice at the lower of the contract price or the publicly advertised sale price.

13. PAYMENT IN ARREARS: Payment in advance is prohibited under this Contract. Payment may only be made after the delivery and acceptance of goods or services. The Vendor shall submit invoices, in arrears.

14. PAYMENT METHODS: Vendor must accept payment by electronic funds transfer and P-card. (The State of West Virginia's Purchasing Card program, administered under contract by a banking institution, processes payment for goods or through the state designated credit cards.)

15. TAXES: The Vendor shall pay any applicable sales, use, personal property or any other taxes arising out of this Contract and the transactions contemplated thereby. The State of West Virginia is exempt from federal and state taxes and will not pay or reimburse such taxes.

16. ADDITIONAL FEES: Vendor is not permitted to charge additional fees or assess additional charges that were not either expressly provided for in the solicitation published by the State of West Virginia or included in the unit price or lump sum bid amount that Vendor is required by the

solicitation to provide. Including such fees or charges as notes to the solicitation may result in rejection of vendor's bid. Requesting such fees or charges be paid after the contract has been awarded may result in cancellation of the contract.

17. FUNDING: This Contract shall continue for the term stated herein, contingent upon funds being appropriated by the Legislature or otherwise being made available. In the event funds are not appropriated or otherwise made available, this Contract becomes void and of no effect beginning on July 1 of the fiscal year for which funding has not been appropriated or otherwise made available.

18. CANCELLATION: The Chief Procurement Officer reserves the right to cancel this Contract immediately upon written notice to the vendor if the materials or workmanship supplied do not conform to the specifications contained in the Contract. The Chief Procurement Office may also cancel any purchase or Contract upon thirty (30) days written notice to the Vendor in accordance with West Virginia Division of Natural Resources Series IV Purchasing Guidelines and Procedures, § 5.2.

19. TIME: Time is of the essence with regard to all matters of time and performance in this Contract.

20. APPLICABLE LAW: This Contract is governed by and interpreted under West Virginia law without giving effect to its choice of law principles. Any information provided in specification manuals, or any other source, verbal or written, which contradicts or violates the West Virginia Constitution, West Virginia Code or West Virginia Code of State Rules is void and of no effect.

21. COMPLIANCE WITH LAWS: Vendor shall comply with all applicable federal, state, and local laws, regulations and ordinances. By submitting a bid, Vendor acknowledges that it has reviewed, understands, and will comply with all applicable laws, regulations, and ordinances.

SUBCONTRACTOR COMPLIANCE: Vendor shall notify all subcontractors providing commodities or services related to this Contract that as subcontractors, they too are required to comply with all applicable laws, regulations, and ordinances. Notification under this provision must occur prior to the performance of any work under the contract by the subcontractor.

22. ARBITRATION: Any references made to arbitration contained in this Contract, Vendor's bid, or in any American Institute of Architects documents pertaining to this Contract are hereby deleted, void, and of no effect.

23. MODIFICATIONS: This writing is the parties' final expression of intent. Notwithstanding anything contained in this Contract to the contrary no modification of this Contract shall be binding without mutual written consent of the Agency, and the Vendor, with approval of the Property and Procurement Office and the Attorney General's office (Attorney General approval is as to form only). Any change to existing contracts that adds work or changes contract cost, and were not included in the original contract, must be approved by the Property and Procurement Office and the Attorney General's Office (as to form) prior to the implementation of the change or commencement of work affected by the change.

24. WAIVER: The failure of either party to insist upon a strict performance of any of the terms or provision of this Contract, or to exercise any option, right, or remedy herein contained, shall not be construed as a waiver or a relinquishment for the future of such term, provision, option, right, or

remedy, but the same shall continue in full force and effect. Any waiver must be expressly stated in writing and signed by the waiving party.

25. SUBSEQUENT FORMS: The terms and conditions contained in this Contract shall supersede any and all subsequent terms and conditions which may appear on any form documents submitted by Vendor to the Agency such as price lists, order forms, invoices, sales agreements, or maintenance agreements, and includes internet websites or other electronic documents. Acceptance or use of Vendor's forms does not constitute acceptance of the terms and conditions contained thereon.

26. ASSIGNMENT: Neither this Contract nor any monies due, or to become due hereunder, may be assigned by the Vendor without the express written consent of the Agency, the Property and Procurement Office, the Attorney General's office (as to form only), and any other government agency or office that may be required to approve such assignments.

27. WARRANTY: The Vendor expressly warrants that the goods and/or services covered by this Contract will: (a) conform to the specifications, drawings, samples, or other description furnished or specified by the Agency; (b) be merchantable and fit for the purpose intended; and (c) be free from defect in material and workmanship.

28. STATE EMPLOYEES: State employees are not permitted to utilize this Contract for personal use and the Vendor is prohibited from permitting or facilitating the same.

29. BANKRUPTCY: In the event the Vendor files for bankruptcy protection, the State of West Virginia may deem this Contract null and void and terminate this Contract without notice.

30. PRIVACY, SECURITY, AND CONFIDENTIALITY: The Vendor agrees that it will not disclose to anyone, directly or indirectly, any such personally identifiable information or other confidential information gained from the Agency, unless the individual who is the subject of the information consents to the disclosure in writing or the disclosure is made pursuant to the Agency's policies, procedures, and rules. Vendor further agrees to comply with the Confidentiality Policies and Information Security Accountability Requirements, set forth in <http://www.state.wv.us/admin/purchase/privacy/default.html>.

31. YOUR SUBMISSION IS A PUBLIC DOCUMENT: Vendor's entire response to the Solicitation and the resulting Contract are public documents. As public documents, they will be disclosed to the public following the bid/proposal opening or award of the contract, as required by the competitive bidding laws of W. Va. Code §§ 5A-3-1 et seq., 5-22-1 et seq., and 5G-1-1 et seq. and the Freedom of Information Act W. Va. Code §§ 29B-1-1 et seq.

DO NOT SUBMIT MATERIAL YOU CONSIDER TO BE CONFIDENTIAL, A TRADE SECRET, OR OTHERWISE NOT SUBJECT TO PUBLIC DISCLOSURE.

Submission of any bid, proposal, or other document to the Property and Procurement Office constitutes your explicit consent to the subsequent public disclosure of the bid, proposal, or document. The Property and Procurement Office will disclose any document labeled "confidential," "proprietary," "trade secret," "private," or labeled with any other claim against public disclosure of the documents, to include any "trade secrets" as defined by W. Va. Code § 47-22-1 et seq. All submissions are subject to public disclosure without notice.

32. LICENSING: In accordance with West Virginia Division of Natural Resources Series IV Purchasing Guidelines and Policies, §6.1.d.1., Vendor must be licensed and in good standing in accordance with any and all state and local laws and requirements by any state or local agency of West Virginia, including, but not limited to, the West Virginia Secretary of State's Office, the West Virginia Tax Department, West Virginia Insurance Commission, or any other state agency or political subdivision. Upon request, the Vendor must provide all necessary releases to obtain information to enable the Property and Procurement Office's Chief Procurement Officer or the Agency to verify that the Vendor is licensed and in good standing with the above entities.

SUBCONTRACTOR COMPLIANCE: Vendor shall notify all subcontractors providing commodities or services related to this Contract that as subcontractors, they too are required to be licensed, in good standing, and up-to-date on all state and local obligations as described in this section. Obligations related to political subdivisions may include, but are not limited to, business licensing, business and occupation taxes, inspection compliance, permitting, etc. Notification under the provision must occur prior to performance of any work under the contract by the subcontractor.

33. ANTITRUST: In submitting a bid to, signing a contract with, or accepting an Award Document from any agency of the State of West Virginia, the Vendor agrees to convey, sell, assign, or transfer to the State of West Virginia all rights, title, and interest in and to all causes of action it may now or hereafter acquire under the antitrust laws of the United States and the State of West Virginia for price fixing and/or unreasonable restraints of trade relating to the particular commodities or services purchased or acquired by the State of West Virginia. Such assignment shall be made and become effective at the time the purchasing agency tenders the initial payment to Vendor.

34. VENDOR CERTIFICATIONS: By signing its bid or entering into this Contract, Vendor certifies (1) that its bid or offer was made without prior understanding, agreement, or connection with any corporation, firm, limited liability company, partnership, person or entity submitting a bid or offer for the same material, supplies, equipment or services; (2) that its bid or offer is in all respects fair and without collusion or fraud; (3) that this Contract is accepted or entered into without any prior understanding, agreement, or connection to any other entity that could be considered a violation of law; and (4) that it has reviewed this Solicitation in its entirety; understands the requirements, terms and conditions, and other information contained herein.

Vendor's signature on its bid or offer also affirms that neither it nor its representatives have any interest, nor shall acquire any interest, direct or indirect, which would compromise the performance of its services hereunder. Any such interests shall be promptly presented in detail to the Agency. The individual signing this bid or offer on behalf of Vendor certifies that he or she is authorized by the Vendor to execute this bid or offer or any documents related thereto on Vendor's behalf; that he or she is authorized to bind the Vendor in a contractual relationship; and that, to the best of his or her knowledge, the Vendor has properly registered with any State agency that may require registration.

35. VENDOR RELATIONSHIP: The relationship of the Vendor to the State shall be that of an independent contractor and no principal-agent relationship or employer-employee relationship is contemplated or created by this Contract. The Vendor as an independent contractor is solely liable for the acts and omissions of its employees and agents. Vendor shall be responsible for selecting, supervising, and compensating any and all individuals employed pursuant to the terms of this Solicitation and resulting contract. Neither the Vendor, nor any employees or subcontractors of the

Vendor, shall be deemed to be employees of the State for any purpose whatsoever. Vendor shall be exclusively responsible for payment of employees and contractors for all wages and salaries, taxes, withholding payments, penalties, fees, fringe benefits, professional liability insurance premiums, contributions to insurance and pension, or other deferred compensation plans, including but not limited to, Workers' Compensation and Social Security obligations, licensing fees, etc. and the filing of all necessary documents, forms, and returns pertinent to all of the foregoing.

Vendor shall hold harmless the State and shall provide the State and Agency with a defense against any and all claims including, but not limited to, the foregoing payments, withholdings, contributions, taxes, Social Security taxes, and employer income tax returns.

36. INDEMNIFICATION: The Vendor agrees to indemnify, defend, and hold harmless the State and the Agency, their officers, and employees from and against: (1) Any claims or losses for services rendered by any subcontractor, person, or firm performing or supplying services, materials, or supplies in connection with the performance of the Contract; (2) Any claims or losses resulting to any person or entity injured or damaged by the Vendor, its officers, employees, or subcontractors by the publication, translation, reproduction, delivery, performance, use, or disposition of any data used under the Contract in a manner not authorized by the Contract, or by Federal or State statutes or regulations; and (3) Any failure of the Vendor, its officers, employees, or subcontractors to observe State and Federal laws including, but not limited to, labor and wage and hour laws.

37. PURCHASING AFFIDAVIT: In accordance with West Virginia Code §5A-3-10a and 5-22-1(i), the State is prohibited from awarding a contract to any bidder that owes a debt to the State or to a political subdivision of the State. Vendors are required to sign, notarize, and submit the Purchasing Affidavit to the Agency affirming under oath that it is not in default on any monetary obligation owed to the State or a political subdivision of the State.

38. ADDITIONAL AGENCY AND LOCAL GOVERNMENT USE: This Contract may be utilized by other agencies, spending units, and political subdivisions of the State of West Virginia; county, municipal, and other local government bodies; and school districts ("Other Government Entities"). Any extension of this Contract to the aforementioned, Other Government Entities must be on the same prices, terms, and conditions as those offered and agreed to in this Contract, provided that such extension is in compliance with the applicable laws, rules, and ordinances of the Other Government Entity. If the Vendor does not wish to extend the prices, terms, and conditions of its bid and subsequent contract to the Other Government Entities, the Vendor must clearly indicate such refusal in its bid. A refusal to extend this Contract to the Other Government Entities shall not impact or influence the award of this Contract in any manner.

39. CONFLICT OF INTEREST: Vendor, its officers or members or employees, shall not presently have or acquire an interest, direct or indirect, which would conflict with or compromise the performance of its obligations hereunder. Vendor shall periodically inquire of its officers, members, and employees to ensure that a conflict of interest does not arise. Any conflict of interest discovered shall be promptly presented in detail to the Agency.

40. REPORTS: Vendor shall provide the Agency with the following reports identified by a checked box below:

Such reports as the Agency may request. Requested reports may include, but are not limited to, quantities purchased, agencies utilizing the contract, total contract expenditures by agency, etc.

Quarterly reports detailing the total quantity of purchases in units and dollars, along with a listing of purchases by agency.

41. PREFERENCE FOR USE OF DOMESTIC STEEL PRODUCTS: Except when authorized by the Director of the Purchasing Division pursuant to W. Va. Code § 5A-3-56, no contractor may use or supply steel products for a State Contract Project other than those steel products made in the United States. A contractor who uses steel products in violation of this section may be subject to civil penalties pursuant to W. Va. Code § 5A-3-56. As used in this section:

- a. "State Contract Project" means any erection or construction of, or any addition to, alteration of or other improvement to any building or structure, including, but not limited to, roads or highways, or the installation of any heating or cooling or ventilating plants or other equipment, or the supply of and materials for such projects, pursuant to a contract with the State of West Virginia for which bids were solicited on or after June 6, 2001.
- b. "Steel Products" means products rolled, formed, shaped, drawn, extruded, forged, cast, fabricated or otherwise similarly processed, or processed by a combination of two or more or such operations, from steel made by the open hearth, basic oxygen, electric furnace, Bessemer or other steel making process. The Purchasing Division Director may, in writing, authorize the use of foreign steel products if:
- c. The cost for each contract item used does not exceed one tenth of one percent (.1%) of the total contract cost or two thousand five hundred dollars (\$2,500.00), whichever is greater. For the purposes of this section, the cost is the value of the steel product as delivered to the project; or
- d. The Director of the Purchasing Division determines that specified steel materials are not produced in the United States in sufficient quantity or otherwise are not reasonably available to meet contract requirements.

42. PREFERENCE FOR USE OF DOMESTIC ALUMINUM, GLASS, AND STEEL: In accordance with W. Va. Code § 5-19-1 et seq., and W. Va. CSR § 148-10-1 et seq., for every contract or subcontract, subject to the limitations contained herein, for the construction, reconstruction, alteration, repair, improvement or maintenance of public works or for the purchase of any item of machinery or equipment to be used at sites of public works, only domestic aluminum, glass or steel products shall be supplied unless the spending officer determines, in writing, after the receipt of offers or bids, (1) that the cost of domestic aluminum, glass or steel products is unreasonable or inconsistent with the public interest of the State of West Virginia, (2) that domestic aluminum, glass or steel products are not produced in sufficient quantities to meet the contract requirements, or (3) the available domestic aluminum, glass, or steel do not meet the contract specifications. This provision only applies to public works contracts awarded in amount more than fifty thousand dollars (\$50,000) or public works contracts that require more than ten thousand pounds of steel products.

The cost of domestic aluminum, glass, or steel products may be unreasonable if the cost is more than twenty percent (20%) of the bid or offered price for foreign made aluminum, glass, or steel products. If the domestic aluminum, glass or steel products to be supplied or produced in a "substantial labor surplus area", as defined by the United States Department of Labor, the cost of domestic aluminum, glass, or steel products may be unreasonable if the cost is more than thirty percent (30%) of the bid or offered price for foreign made aluminum, glass, or steel products.

This preference shall be applied to an item of machinery or equipment, as indicated above, when the item is a single unit of equipment or machinery manufactured primarily of aluminum, glass or

steel, is part of a public works contract and has the sole purpose or of being a permanent part of a single public works project. This provision does not apply to equipment or machinery purchased by a spending unit for use by that spending unit and not as part of a single public works project.

All bids and offers including domestic aluminum, glass or steel products that exceed bid or offer prices including foreign aluminum, glass or steel products after application of the preferences provided in this provision may be reduced to a price equal to or lower than the lowest bid or offer price for foreign aluminum, glass or steel products plus the applicable preference. If the reduced bid or offer prices are made in writing and supersede the prior bid or offer prices, all bids or offers, including the reduced bid, or offer prices, will be reevaluated in accordance with this rule.

43. INTERESTED PARTY SUPPLEMENTAL DISCLOSURE: W. Va. Code § 6D-1-2 requires that for contracts with an actual or estimated value of at least \$1 million, the vendor must submit to the Agency a supplemental disclosure of interested parties reflecting any new or differing interested parties to the contract, which were not included in the original preaward interested party disclosure, within 30 days following the completion or termination of the contract. A copy of that form is included with this solicitation or can be obtained from the WV Ethics Commission. This requirement does not apply to publicly traded companies listed on a national or international stock exchange. A more detailed definition of interested parties can be obtained from the form referenced above.

DESIGNATED CONTACT: Vendor appoints the individual identified in this Section as the Contract Administrator and the initial point of contact for matters relating to this Contract.

JoJo Lambiotte, Business Development Manager

(Name, Title)

JoJo Lambiotte, Business Development Manager

(Printed Name and Title)

1115 East High Street Waynesburg, PA

(Address)

(724)627-3757 / (724)852-1798

(Phone Number) / (Fax Number)

jlambiotte@jacobspetro.com

(email address)

CERTIFICATION AND SIGNATURE: By signing below, or submitting documentation through wvOASIS, I certify that I have reviewed this Solicitation in its entirety; that I understand the requirements, terms and conditions, and other information contained herein; that this bid, offer or proposal constitutes an offer to the State that cannot be unilaterally withdrawn; that the product or service proposed meets the mandatory requirements contained in the Solicitation for that product or service, unless otherwise stated herein; that the Vendor accepts the terms and conditions contained in the Solicitation, unless otherwise stated herein; that I am submitting this bid, offer or proposal for review and consideration; that I am authorized by the vendor to execute and submit this bid, offer, or proposal, or any documents related thereto on vendor's behalf; that I am authorized to bind the vendor in a contractual relationship; and that to the best of my knowledge, the vendor has properly registered with any State agency that may require registration.

Stuck Enterprises

(Company)

 Business Development Manager

(Authorized Signature) (Representative Name, Title)

JoJo Lambiotte, Business Development Manager

(Printed Name and Title of Authorized Representative)

3-4-20

(Date)

(724)627-3757 / (724)852-1798

(Phone Number) (Fax Number)

REQUEST FOR QUOTATION
West Virginia Division of Natural Resources – State Parks and Recreation
Cacapon Resort State Park- Open End Propane Contract

SPECIFICATIONS

1. **PURPOSE AND SCOPE:** The West Virginia Division of Natural Resources is soliciting bids on behalf of the Parks and Recreation Section to establish an Open-End contract for propane at Cacapon Resort State Park. The contract will include equipment, installation, maintenance, fill and refill of propane tanks for the Park located at 818 Cacapon Lodge Drive, Berkeley Springs, WV 25411 in Morgan County.
2. **DEFINITIONS:** The terms listed below shall have the meanings assigned to them below. Additional definitions can be found in section 2 of the General Terms and Conditions.
 21. **“Contract Item” or “Contract Items”** means the list of items identified in Agency 3.1 below and on the Pricing Pages.
 22. **“OPIS”** means Oil Price Information Service as published by United Communications Group, 1300 Rockville Pike, Suite 1100, Rockville, MD 20852 1-800-929-4824.
 23. **“Pricing Pages”** means the schedule of prices, estimated order quantity, and totals contained in wvOASIS or attached hereto as Exhibit A, upon which Vendor should list its proposed price for the Contract Services.
 24. **“Solicitation”** means the official notice of an opportunity to supply the State with goods or services that is published by the West Virginia Division of Natural Resources.
 25. **“The Park”** means Cacapon Resort State Park.
 26. **“Usage Requirements”** means the amount of propane necessary for the operation of Cacapon Resort State Park.

3. **GENERAL REQUIREMENTS:**

Contract Items and Mandatory Requirements: Vendor shall provide Agency with the Contract Items listed below on an open-end and continuing basis. Contract Items must meet or exceed the mandatory requirements as shown below.

- 3.1 On demand Vendor must provide and install: four (4) one thousand (1000) gallon tanks, fifteen (15) five hundred (500) gallon tanks, one (1) five hundred (500) gallon underground tank, one (1) one hundred twenty-four (124) gallon tank and twenty-one (21) one hundred twenty (120) gallon tanks as set forth on the attached map *Exhibit B*.
 - 3.1.1 Tanks shall be set, but not affixed to concrete pavers near the facility in which they will service.

REQUEST FOR QUOTATION
West Virginia Division of Natural Resources – State Parks and Recreation
Cacapon Resort State Park- Open End Propane Contract

- 3.1.2** Contract includes all labor and material for removal of existing Vendor units. Contract includes all labor and material for installation of new Vendor units.
- 3.1.2.1** One (1) Five hundred (500) gallon underground tank will be dug up, if it is replaced.
- 3.1.3** **Vendor is responsible to the point where service enters the building.** Vendor must be responsible for all exterior equipment which includes tanks, lines and regulators to the building in which the tank serves.
- 3.1.3.1** Contract must include service and maintenance of all supplies and equipment to the exterior of the facility that is serviced which includes tanks, lines and regulators.
- 3.1.4** **The Park will be responsible for the interior equipment, which is defined as the interior gas lines, ranges, ovens, heaters, fireplaces, tank-less on demand water heaters and furnaces.**
- 3.2** Vendor shall fill eighteen (18) State owned one thousand (1000) gallon tanks located at “tank farm”. *(See map Exhibit B).*
- 3.2.1** **Vendor is responsible for equipment from State owned tank to the point where service enters the building.** Vendor is responsible for all exterior equipment, excluding the State owned tanks, which includes lines and regulators to the building in which the State tank serves.
- 3.2.1.1** Contract must include service and maintenance of all supplies and equipment to the exterior of the facility that is serviced which includes tanks, lines and regulators.
- 3.3** Usage of propane varies by demand due to weather conditions and park visitation. Usage is defined as propane sufficient to meet said demand.
- 3.4** Vendor must provide a twenty-four (24) hour emergency response number. Emergency response number must be affixed to the exterior of each tank and readily visible.
- 3.5** Vendor must place the facility on an “automatic fill” program. The object of the automatic fill program is to eliminate the need for Agency personnel to monitor fuel levels and place orders, while at the same time not running the risk of being without fuel. It is the intent of the Agency that “manual” orders of this type to be the exception and shall only be used in other than normal circumstances.

REQUEST FOR QUOTATION
West Virginia Division of Natural Resources – State Parks and Recreation
Cacapon Resort State Park- Open End Propane Contract

- 3.5.1** Vendor must replenish the Parks fuel tanks automatically without an order being placed by the Agency personnel. Automatic refill schedule will be established once the Agency and Vendor have determined accurate delivery timeframes.
- 3.5.2** Vendor is responsible for maintaining a program to have sufficient LP gas for use by the Park thus to minimize the possibility of emergency fuel deliveries. The Park will not pay additional fees for emergency fuel deliveries due to the Vendor's failure to provide sufficient LP gas.
- 3.6** The Vendor, along with assistance from the Park, will be responsible for the coordination of the changeover of exterior equipment with the current vendor. The changeover may consist of any existing tanks, transfer, replacement, etc. with the current vendor, to assure safe transfer in accordance with all Federal, State, County and local governing regulations and codes.
- 3.6.1** Unused propane product removed during installation, and not transferred into any new Vendor tanks must be credited to Cacapon Resort State Park at the stated contract price. This procedure must be completed with a metered truck, written down and delivered to Cacapon Resort State Park office.
- 3.6.2** Tanks are to be in good condition, clean, painted and have a valid recertification stamp. Tanks must be set per a schedule that will be provided by the Park in order to mitigate disruption of Park services. Vendor may not disrupt use by Park guests. Lines, regulators and devices as provided by the vendor must be free of defects or shall be repaired immediately.
- 3.6.3** Removal of equipment, and or supplies, shall be at no expense to the Park. Any damage or unsafe condition caused by removal must be repaired immediately and at no charge to the Park.
- 3.7** A winter additive, or sufficient sizing of regulator as provided by the Vendor for wintry weather to prevent lines from freezing, must be included for all tanks.
- 3.8** Vendors must provide proof of quality of the product provided at any time during the life of the contract. Such proof may include the identity and location of the refiner producing the fuel and the exact specifications/content of the fuel. Vendors must be an established refiner, distributor or dealer. In the event any adulterated or substandard fuel is delivered, all costs associated with the emptying and cleaning of Cacapon Resort State Park tank(s) will be the responsibility of the Vendor.
- 3.8.1** Annual testing of the Vendor owned equipment consisting of valves, regulators, gauges, tanks and any other equipment to ensure proper operations shall be considered and documented by no later than the 15th of January each year.

REQUEST FOR QUOTATION
West Virginia Division of Natural Resources – State Parks and Recreation
Cacapon Resort State Park- Open End Propane Contract

3.8.2 Replacement of defective equipment shall be done immediately at no additional cost to the Park. Proof of testing must be provided to the Park within thirty (30) days of said testing, at no additional cost to the Park. Testing results are subject to the approval of the Park.

3.9 Vendor will be responsible for securing ALL required governmental and jurisdictional permits required at no cost to the Park.

3.10 Vendor must be licensed with the state of West Virginia State Tax office as a refiner, distributor, or dealer for propane. Vendor should provide with their submitted bid response, a copy of their licenses. This documentation will be required before contract award.

4. CONTRACT AWARD:

4.1 Contract Award: The Contract is intended to provide the Agency with a purchase price on all Contract Items. The Contract shall be awarded to the Vendor that provides the Contract Items meeting the required specifications for the lowest overall total bid amount as shown on *Exhibit A-Pricing Page*.

4.1.1 All prices quoted must be the delivered price to any location within Cacapon Resort State Park, 818 Cacapon Lodge Drive, Berkeley Springs, WV 25411 in Morgan County, WV.

4.1.2 Vendors must bid a "Firm Fixed Mark-Up Price" per gallon on fuel, inclusive of all delivery costs. The vendor is to be paid only a firm fixed mark-up for business profit and expenses in supplying product to the Park. Product price is tied to OPIS.

4.1.3 Product cost shall be the "Firm Fixed Mark-Up" Bid price plus the Oil Price Information Service (OPIS) weekly newsletter published price for the week proceeding delivery. OPIS is published by the United Communications Group, 11300 Rockville Pike, Suite 1100, Rockville, MD 20852. Telephone number: (800) 929-4824. Vendor shall be required to submit proof of cost in conduction with the submission of invoices. A copy of the pages(s) showing the date and the cost will be acceptable.

4.1.4 In the event of an emergency, and because the Park has limited resources, the contract, terms and pricing remain in full force and effect. During such emergencies, priority to Cacapon Resort State Park must be maintained.

REQUEST FOR QUOTATION
West Virginia Division of Natural Resources – State Parks and Recreation
Cacapon Resort State Park- Open End Propane Contract

5. **Pricing Pages:** Vendor should complete Exhibit A-Pricing Page by filling all areas that are shaded. Vendor should complete the Pricing Page in its entirety, as failure to do so may result in Vendor's bids being disqualified.

****Vendor must identify the Terminal which they are pulling their information from on their Bid Pricing Sheet- Exhibit A (Vendor Proposed Pull Terminal). ****

- 51 Pricing Page contains a list of the Contract Items and estimated purchase volume. The estimated purchase volume for each item represents the approximate volume of anticipated purchases only.

Items 1 through 11: Estimated Tanks (multiplied by) Cost per Unit (equals) Extended Price. Total for Subtotal "A"

Item 12: Enter the name of the Proposed OPIS Pull Terminal.

Estimated OPIS Propane Index Price of \$2.67 (plus) Vendor Mark Up (equals) Unit Cost. (multiplied by) Estimated Quantity of 155,000 gallons (equals) Estimated Amount (Subtotal "B").

- 52 No future use of the contract or any individual item is guaranteed or implied.
- 53 Vendor should electronically enter the information into the pricing page through wvOASIS, if available, or as an electronic document. Vendor can download the Excel version of the pricing page from the wvOASIS VSS website for this solicitation.

If submitting online, Vendor is to enter the TOTAL BID AMOUNT from Exhibit A-Pricing Page in the wvOASIS Commodity line when submitting bid response and include Exhibit A-Pricing Page as an attachment before submitting.

6. ORDERING AND PAYMENT:

- 61 **Ordering:** Vendor shall accept orders through facsimile, e-mail, or any other written form of communication. Vendor may, but is not required to, accept on-line orders through a secure internet ordering portal/website. If Vendor has the ability to accept on-line orders, it should include in its response a brief description of how the Agency may utilize the on-line ordering system. Vendor shall ensure that its on-line ordering system is properly secured prior to processing Agency orders on-line.
- 62 **Payment:** Vendor shall accept payment in accordance with the payment procedures of the State of West Virginia and acceptance of State of West Virginia Purchasing Card is required.

REQUEST FOR QUOTATION
West Virginia Division of Natural Resources – State Parks and Recreation
Cacapon Resort State Park- Open End Propane Contract

- 6.2.1 Vendor must submit a separate invoice for each individual tank with the tank noted. Please see attached map (*Exhibit B*) for tank locations and sizes at the Park. Tanks should be identified on the invoice by describing the exact location of the tank and the size of the tank.
- 6.2.2 Invoices must be itemized and cannot include items not covered under this contract.
- 6.2.3 Vendor to provide, at invoice time, the meter of each tank before and after filling.
- 6.2.4 A running total of each tank's demand is required and must be provided to the Park at no additional charge at the end of the contract.

7. DELIVERY AND RETURN:

- 7.1 **Delivery Time:** Vendor shall formulate with the Park a delivery schedule to maintain adequate levels of LP gas. Vendor shall also be required to deliver propane upon demand.
 - 7.1.1 Vendor shall set up equipment and provide propane service within forty-five (45) days upon receipt of notice to proceed.
- 7.2 **Late Delivery:** Cacapon Resort State Park, under this Contract, must be notified by phone to the Lodge Office at 304-258-1022 and in writing if orders will be delayed for any reason. Any delay in delivery that could cause harm to the Park will be grounds for cancellation of the delayed order, and/or obtaining the items ordered from a third party.

Any Section seeking to obtain items from a third party under this provision must first obtain approval of the Chief Procurement Officer.
- 7.3 **Delivery Payment/Risk of Loss:** Standard order delivery shall be F.O.B. destination to the Agency's location. Vendor shall include the cost of standard order delivery charges in its bid pricing/discount and is not permitted to charge the Agency separately for such delivery. The Park will not pay extra delivery charge for emergency orders, see line 3.5.2.
- 7.4 **Return of Unacceptable Items:** If the Agency deems the Contract Items to be unacceptable, the Contract Items shall be returned to Vendor at Vendor's expense and with no restocking charge. Vendor shall make immediate arrangements for the return upon notification that items are unacceptable see *section 3.8*. If the original packaging cannot be utilized for the return, Vendor will supply the Agency with appropriate return packaging upon request. All returns of unacceptable items shall be F.O.B. the Agency's location. The returned product shall either be replaced, or the Agency shall receive a full credit or refund for the purchase price, at the Agency's discretion.

REQUEST FOR QUOTATION
West Virginia Division of Natural Resources – State Parks and Recreation
Cacapon Resort State Park- Open End Propane Contract

- 75 Return Due to Agency Error:** Items ordered in error by the Agency will be returned for credit within 30 days of receipt, F.O.B. Vendor's location. Vendor shall not charge a restocking fee if returned products are in a resalable condition. Items shall be deemed to be in a resalable condition if they are unused and in the original packaging. Any restocking fee for items not in a resalable condition shall be the lower of the Vendor's customary restocking fee or 5% of the total invoiced value of the returned items.

8. VENDOR DEFAULT:

- 81** The following shall be considered a Vendor default under this Contract.
- 8.1.1** Failure to provide Contract Items in accordance with the requirements contained herein.
 - 8.1.2** Failure to comply with other specifications and requirements contained herein.
 - 8.1.3** Failure to comply with any laws, rules, and ordinances applicable to the Contract Services provided under this Contract.
 - 8.1.4** Failure to remedy deficient performance upon request.
- 82** The following remedies shall be available to Agency upon default.
- 8.2.1** Immediate cancellation of the Contract.
 - 8.2.2** Immediate cancellation of one or more release orders issued under this Contract.
 - 8.2.3** Any other remedies available in law or equity.

9. MISCELLANEOUS:

- 91 No Substitutions:** Vendor shall supply only Contract Items submitted in response to the Solicitation unless a contract modification is approved in accordance with the provisions contained in this Contract.
- 92 Vendor Supply:** Vendor must carry sufficient inventory of the Contract Items being offered to fulfill its obligations under this Contract. By signing its bid, Vendor certifies that it can supply the Contract Items contained in its bid response.
- 93 Reports:** Vendor shall provide quarterly reports and annual summaries to the Agency showing the Agency's items purchased, quantities of items purchased, and total dollar value of the items purchased. Vendor shall also provide reports, upon request, showing the items purchased during the term of this Contract, the quantity purchased for each of

REQUEST FOR QUOTATION
West Virginia Division of Natural Resources – State Parks and Recreation
Cacapon Resort State Park- Open End Propane Contract

those items, and the total value of purchases for each of those items. Failure to supply such reports may be grounds for cancellation of this Contract.

- 94 Contract Manager:** During its performance of this Contract, Vendor must designate and maintain a primary contract manager responsible for overseeing Vendor's responsibilities under this Contract. The Contract Manager must be available during normal business hours to address any customer service or other issues related to this Contract. Vendor should list its Contract manager and his or her contact information below.

Contract Manager: JoJo Lambiotte

Telephone Number: 681-285-1111

Fax Number: 724-852-1798

Email Address: jlambiotte@jacobspetro.com

24 Hour EMERGENCY Response:

Name: Dispatch / Office

Number: 724-627-3757

ADDENDUM ACKNOWLEDGEMENT FORM
SOLICITATION NO.: ARFQ DNR20*32

Instructions: Please acknowledge receipt of all addenda issued with this solicitation by completing this addendum acknowledgment form. Check the box next to each addendum received and sign below. Failure to acknowledge addenda may result in bid disqualification. Acknowledgment: I hereby acknowledge receipt of the following addenda and have made the necessary revisions to my proposal, plans and/or specification, etc.

Addendum Numbers Received:

(Check the box next to each addendum received)

- Addendum No. 1
- Addendum No. 2
- Addendum No. 3
- Addendum No. 4
- Addendum No. 5

- Addendum No. 6
- Addendum No. 7
- Addendum No. 8
- Addendum No. 9
- Addendum No. 10

I understand that failure to confirm the receipt of addenda may be cause for rejection of this bid. I further understand that any verbal representation made or assumed to be made during any oral discussion held between Vendor's representatives and any state personnel is not binding. Only the information issued in writing and added to the specifications by an official addendum is binding.

Stuck Enterprises
Company

JoJo Lambiotte
Authorized Signature

3-4-20
Date

NOTE: This addendum acknowledgment should be submitted with the bid to expedite document processing.

EXHIBIT A – Pricing Page

West Virginia Division of
Natural Resources

Cacapon Resort State Park
Open End Propane Service

**Quantities are estimates only. Actual needs of the Agency must be met whether greater, or less than those listed.*

Item	Tank Size	Description	Estimated Tanks	Cost per Unit	Extended Price
1	120 Gallon	Installation	21	\$100.00	\$2100.00
2	124 Gallon	Installation	1	\$100.00	\$100.00
3	500 Gallon	Installation	15	\$100.00	\$1500.00
4	500 Gallon	Underground Installation	1	\$600.00	\$600.00
5	1000 Gallon	Installation	4	\$100.00	\$400.00
6	120 Gallon	Rental per Month	21	\$0.00	\$0.00
7	124 Gallon	Rental per Month	1	\$0.00	\$0.00
8	500 Gallon	Rental per Month	15	\$0.00	\$0.00
9	500 Gallon	Underground Tank Rental per Month	1	\$0.00	\$0.00
10	1000 Gallon	Rental per Month	4	\$0.00	\$0.00
11	State Owned Tanks	Maintenance per Month	18	\$200.00	\$200 2400.00 per year
				Subtotal "A"	\$7300.00 \$4,900.00

Shading indicates Vendor input required.

Item	Description	Unit of Measure	Vendor Proposed Pull Terminal	Estimated OPIS Propane Index Price	Vendor Mark Up	Unit Cost	Estimated Quantity* (Gallons per year)	Estimated Amount (Subtotal "B")
12	Propane LP Gas	Per Gallon	MONT BELVIEU	\$2.67	\$0.72	\$3.39	155,000*	\$525,450.00
Subtotal "A"								\$7300.00 \$4,900.00
Subtotal "A" + Subtotal "B" =								\$532,750.00
TOTAL BID AMOUNT								\$533,750.00

- Items numbered 1 through 5 are for removal of existing tanks and complete installation of Vendor tanks and equipment. If no cost to Park, enter \$0.00
- Items numbered 6 through 10 are for monthly fee of Vendor tanks and equipment. If no cost to Park, enter \$0.00
- Item Number 11 is for maintenance of eighteen (18) State owned tanks and equipment. If no cost to Park, enter \$0.00
- Enter unit cost, calculate extended price and total for **Subtotal "A"**.
- Item Number 12 enter name of the Proposed Pull Terminal, Vendor will use. Enter a fixed amount for the mark-up (no percentage rate).
- Calculate the Unit Cost (by adding Estimated OPIS Price plus the Mark-Up). Multiply the unit cost by the estimated quantity per year for **Subtotal "B"**

Corrected Total Bid Amount: **\$530,350.00**

Stuck Enterprises

Vendor

Jo Jo Lambiotte
Authorized Vendor Signature

3-4-20

Date

WinterView

- = 1, 2, 3, 4, 5, 6, 7, 8, 9, 10, 11, 12
- = 13, 14, 15, 16, 17, 18, 19, 20, 21, 22, 23, 24, 25, 26, 27, 28, 29, 30, 31, 32
- = 33, 34, 35, 36, 37, 38, 39, 40, 41, 42, 43, 44, 45, 46, 47, 48, 49, 50, 51, 52, 53, 54, 55, 56, 57, 58, 59, 60, 61, 62, 63, 64, 65, 66, 67, 68, 69, 70, 71, 72, 73, 74, 75, 76, 77, 78, 79, 80, 81, 82, 83, 84, 85, 86, 87, 88, 89, 90, 91, 92, 93, 94, 95, 96, 97, 98, 99, 100
- = 101, 102, 103, 104, 105, 106, 107, 108, 109, 110, 111, 112, 113, 114, 115, 116, 117, 118, 119, 120, 121, 122, 123, 124, 125, 126, 127, 128, 129, 130, 131, 132, 133, 134, 135, 136, 137, 138, 139, 140, 141, 142, 143, 144, 145, 146, 147, 148, 149, 150, 151, 152, 153, 154, 155, 156, 157, 158, 159, 160, 161, 162, 163, 164, 165, 166, 167, 168, 169, 170, 171, 172, 173, 174, 175, 176, 177, 178, 179, 180, 181, 182, 183, 184, 185, 186, 187, 188, 189, 190, 191, 192, 193, 194, 195, 196, 197, 198, 199, 200

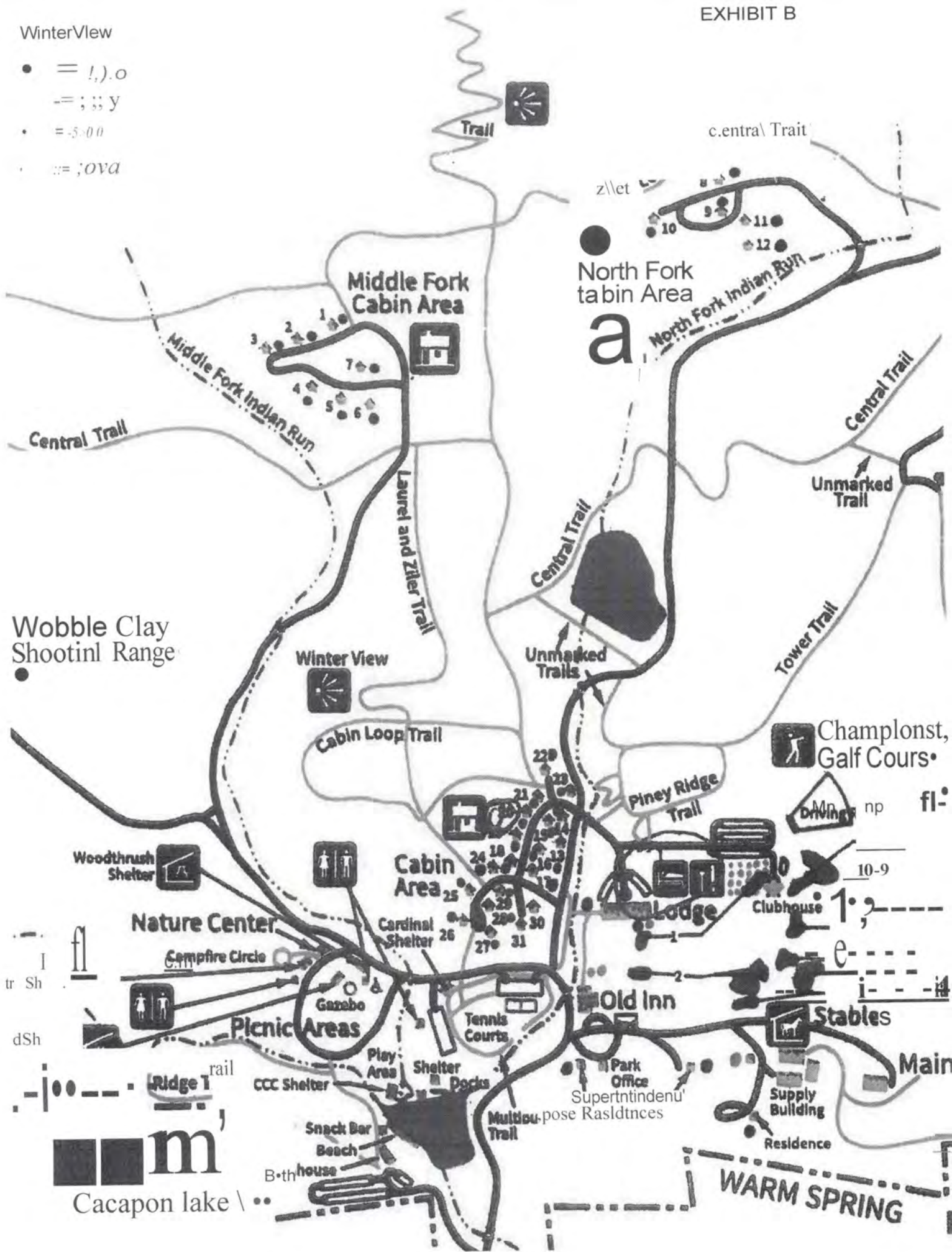

m
Cacapon lake

WARM SPRING

Exhibit C

Cacapon Resort State Park

Tank Ownership • Location • Size

VENDOR SUPPLIED PROPANE TANKS

Tank Size	Quantity	Tank Size	Quantity
120 Gallon Propane Tank	21	500 Gallon Propane Tank	16
124 Gallon Propane Tank	1	1000 Gallon Propane Tank	4

PLACEMENT FOR VENDOR SUPPLIED TANKS

Location	Tank Size	Location	Tank Size
Lodge Restaurant	(1) 120 & (1) 1000	Cabin 31	120
Cabin 1	120	Bath House	124
Cabin 2	120	Cabin 13	500
Cabin 3	120	Cabin 14	500
Cabin 4	120	Cabin 15	500
Cabin 5	120	Cabin 16	500
Cabin 6	120	Cabin 17	500
Cabin 7	120	Cabin 18	500
Cabin 8	120	Cabin 19	500
Cabin 9	120	Cabin 20	500
Cabin 10	120	Cabin 21	500
Cabin 11	120	Cabin 22	500
Cabin 12	120	Cabin 23	500
Cabin 24	120	Superintendent	500
Cabin 25	120	Assistant Superintendent	500
Cabin 26	120	Shooting Range	500
Cabin 27	120	Lounge (underground)	500
Cabin 28	120	Ranger's Cabin	500
Cabin 29	120	Laundry	1000
Cabin 30	120	Old Inn	(2) 1000

STATE OWNED PROPANE TANKS

Location	Tank Size
Main Lodge	(18) 1000

STATE OF WEST VIRGINIA
Purchasing Division

PURCHASING AFFIDAVIT

CONSTRUCTION CONTRACTS: Under W. Va. Code § 5-22-1(i), the contracting public entity shall not award a construction contract to any bidder that is known to be in default on any monetary obligation owed to the state or a political subdivision of the state, including, but not limited to, obligations related to payroll taxes, property taxes, sales and use taxes, fire service fees, or other fines or fees.

ALL CONTRACTS: Under W. Va. Code §5A-3-10a, no contract or renewal of any contract may be awarded by the state or any of its political subdivisions to any vendor or prospective vendor when the vendor or prospective vendor or a related party to the vendor or prospective vendor is a debtor and: (1) the debt owed is an amount greater than one thousand dollars in the aggregate; or (2) the debtor is in employer default.

EXCEPTION: The prohibition listed above does not apply where a vendor has contested any tax administered pursuant to chapter eleven of the W. Va. Code, workers' compensation premium, permit fee or environmental fee or assessment and the matter has not become final or where the vendor has entered into a payment plan or agreement and the vendor is not in default of any of the provisions of such plan or agreement.

DEFINITIONS:

"Debt" means any assessment, premium, penalty, fine, tax or other amount of money owed to the state or any of its political subdivisions because of a judgment, fine, permit violation, license assessment, defaulted workers' compensation premium, penalty or other assessment presently delinquent or due and required to be paid to the state or any of its political subdivisions, including any interest or additional penalties accrued thereon.

"Employer default" means having an outstanding balance or liability to the old fund or to the uninsured employers' fund or being in policy default, as defined in W. Va. Code § 23-2c-2, failure to maintain mandatory workers' compensation coverage, or failure to fully meet its obligations as a workers' compensation self-insured employer. An employer is not in employer default if it has entered into a repayment agreement with the Insurance Commissioner and remains in compliance with the obligations under the repayment agreement.

"Related party" means a party, whether an individual, corporation, partnership, association, limited liability company or any other form or business association or other entity whatsoever, related to any vendor by blood, marriage, ownership or contract through which the party has a relationship of ownership or other interest with the vendor so that the party will actually or by effect receive or control a portion of the benefit, profit or other consideration from performance of a vendor contract with the party receiving an amount that meets or exceeds five percent of the total contract amount.

AFFIRMATION: By signing this form, the vendor's authorized signer affirms and acknowledges under penalty of law for false swearing (W. Va. Code §61-5-3) that: (1) for construction contracts, the vendor is not in default on any monetary obligation owed to the state or a political subdivision of the state, and (2) for all other contracts, that neither vendor nor any related party owe a debt as defined above and that neither vendor nor any related party are in employer default as defined above, unless the debt or employer default is permitted under the exception above.

WITNESS THE FOLLOWING SIGNATURE:

Vendor's Name: Stuck Enterprises

Authorized Signature: [Signature] Date: 3-4-20

State of Pennsylvania

County of Greene, to-wit:

Taken, subscribed, and sworn to before me this 4th day of March, 2020.

My Commission expires October 17, 2021.

AFFIX SEAL HERE

Commonwealth of Pennsylvania

Notarial Seal
JAMIE PAUL BRADDOCK - Notary Public
WAYNESBURG BORO, GREENE COUNTY
My Commission Expires Oct 17, 2021

NOTARY PUBLIC

[Signature]
Purchasing Affidavit (Revised 01/19/2018)



State of West Virginia
Request For Quotation
Fuels

Procurement Folder : 689178

Document Description : Addendum No 01_Open-End Propane Contract - Cacapon Resort SP

Procurement Type : Agency Master Agreement

Date Issued	Solicitation Closes	Solicitation No	Version	Phase
2020-03-05	2020-03-12 13:30:00	ARFQ 0310 DNR2000000032	2	Final

SUBMIT RESPONSES TO:	VENDOR
BID RESPONSE DIVISION OF NATURAL RESOURCES PROPERTY & PROCUREMENT OFFICE 324 4TH AVE SOUTH CHARLESTON WV 25303-1228 US	Vendor Name, Address and Telephone Stuck Enterprises 1115 EAST HIGH STREET WAYNESBURG PA 724-627-3757

FOR INFORMATION CONTACT THE

James H Adkins
(304) 558-3397
jamie.h.adkins@wv.gov

Signature *JoJo Lambiotte*

FEIN # 25-1305625

DATE 3-9-20

All offers subject to all terms and conditions contained in this solicitation

ADDITIONAL INFORMATION:

Addendum No. 01 is issued to publish and distribute the attached information to the Vendor Community.

INVOICE TO		SHIP TO	
SUPERINTENDENT DIVISION OF NATURAL RESOURCES CACAPON RESORT STATE PARK 818 CACAPON LODGE DR BERKELEY SPRINGS WV25411-3300 US		SUPERINTENDENT DIVISION OF NATURAL RESOURCES CACAPON RESORT STATE PARK 818 CACAPON LODGE DR BERKELEY SPRINGS WV 25411 US	

Line	Commodity Line Description	Qty	Unit Issue	Unit Price	Total Price
1	Propane				

Commodity Code	Manufacturer	Model #	Specification
15111501			

Extended Description

Please see Exhibit A - Pricing Page

SCHEDULE OF EVENTS

Line	Event	Event Date
1	Non-Mandatory Pre-Bid Meeting @ 10 a.m. EST	2020-02-20
2	Technical Question Deadline at 9:00 a.m. EST	2020-02-27

DNR2000000032	Document Phase Final	Document Description Addendum No 01_Open-End Propane Contract - Cacapon Resort SP	Page 3 of 3
---------------	--------------------------------	--	------------------------

ADDITIONAL TERMS AND CONDITIONS

See attached document(s) for additional Terms and Conditions

SOLICITATION NAME: Open-End Propane Contract for Cacapon Resort SP
SOLICITATION NO: ARFQ DNR20*32
ADDENDUM NO: No. 01

The purpose of this addendum is to modify the solicitation identified above to reflect the change(s) identified and described below.

Applicable Addendum Category:

- Modify bid opening date and time
- Modify specifications of product or service being sought
- Attachment of vendor questions and responses
- Attachment of pre-bid sign-in sheet
- Correction of error
- Other

Description of Modification to Solicitation:

1. Addendum issued to modify Bid Opening Date to THURSDAY, MARCH 12, 2020 at 1:30 p.m. EST
No further changes.

Additional Documentation: Documentation related to this Addendum (if any) has been included herewith as Attachment A and is specifically incorporated herein by reference.

Terms and Conditions:

1. All provisions of the Solicitation and other addenda not modified herein shall remain in full force and effect.
2. Vendor should acknowledge receipt of all addenda issued for this Solicitation by completing an Addendum Acknowledgment, a copy of which is included herewith. Failure to acknowledge addenda may result in bid disqualification. The addendum acknowledgement should be submitted with the bid to expedite document processing.

ADDENDUM ACKNOWLEDGEMENT FORM
SOLICITATION NO.: ARFQ DNR20*32

Instructions: Please acknowledge receipt of all addenda issued with this solicitation by completing this addendum acknowledgment form. Check the box next to each addendum received and sign below. Failure to acknowledge addenda may result in bid disqualification. Acknowledgment: I hereby acknowledge receipt of the following addenda and have made the necessary revisions to my proposal, plans and/or specification, etc.

Addendum Numbers Received:

(Check the box next to each addendum received)

- | | | | |
|-------------------------------------|----------------|--------------------------|-----------------|
| <input checked="" type="checkbox"/> | Addendum No. 1 | <input type="checkbox"/> | Addendum No. 6 |
| <input checked="" type="checkbox"/> | Addendum No. 2 | <input type="checkbox"/> | Addendum No. 7 |
| <input type="checkbox"/> | Addendum No. 3 | <input type="checkbox"/> | Addendum No. 8 |
| <input type="checkbox"/> | Addendum No. 4 | <input type="checkbox"/> | Addendum No. 9 |
| <input type="checkbox"/> | Addendum No. 5 | <input type="checkbox"/> | Addendum No. 10 |

I understand that failure to confirm the receipt of addenda may be cause for rejection of this bid. I further understand that any verbal representation made or assumed to be made during any oral discussion held between Vendor's representatives and any state personnel is not binding. Only the information issued in writing and added to the specifications by an official addendum is binding.

Stuck Enterprises

Company

JoJo Lambiotte
Authorized Signature

3-9-20

Date

NOTE: This addendum acknowledgment should be submitted with the bid to expedite document processing.



State of West Virginia
Request For Quotation
Fuels

Procurement Folder : 689178

Document Description : Addendum No 02_Open-End Propane Contract - Cacapon Resort SP

Procurement Type : Agency Master Agreement

Date Issued	Solicitation Closes	Solicitation No	Version	Phase
2020-03-06	2020-03-12 13:30:00	ARFQ 0310 DNR2000000032	3	Final

SUBMIT RESPONSES TO:	VENDOR
BID RESPONSE DIVISION OF NATURAL RESOURCES PROPERTY & PROCUREMENT OFFICE 324 4TH AVE SOUTH CHARLESTON WV 25303-1228 US	Vendor Name, Address and Telephone Stuck Enterprises 1115 East High Street Waynesburg Pa 15370 724-627-3757

FOR INFORMATION CONTACT THE

James H Adkins
(304) 558-3397
jamie.h.adkins@wv.gov

Signature X *JoJo Lambiotte*

FEIN # 25-1305625

DATE 3-9-20

All offers subject to all terms and conditions contained in this solicitation

ADDITIONAL INFORMATION:

Addendum No. 02 is issued to publish and distribute the attached information to the Vendor Community.

INVOICE TO		SHIP TO	
SUPERINTENDENT DIVISION OF NATURAL RESOURCES CACAPON RESORT STATE PARK 818 CACAPON LODGE DR BERKELEY SPRINGS WV25411-3300 US		SUPERINTENDENT DIVISION OF NATURAL RESOURCES CACAPON RESORT STATE PARK 818 CACAPON LODGE DR BERKELEY SPRINGS WV 25411 US	

Line	Commodity Line Description	Qty	Unit Issue	Unit Price	Total Price
1	Propane				

Commodity Code	Manufacturer	Model #	Specification
15111501			

Extended Description
Please see Exhibit A - Pricing Page

SCHEDULE OF EVENTS

Line	Event	Event Date
1	Non-Mandatory Pre-Bid Meeting @ 10 a.m. EST	2020-02-20
2	Technical Question Deadline at 9:00 a.m. EST	2020-02-27

DNR2000000032	Document Phase Final	Document Description Addendum No 02_Open-End Propane Contract - Cacapon Resort SP	Page 3 of 3
---------------	--------------------------------	--	------------------------------

ADDITIONAL TERMS AND CONDITIONS

See attached document(s) for additional Terms and Conditions

SOLICITATION NAME: Open-End Propane Contract for Cacapon Resort SP
SOLICITATION NO: ARFQ DNR20*32
ADDENDUM NO: No. 02

The purpose of this addendum is to modify the solicitation identified above to reflect the change(s) identified and described below.

Applicable Addendum Category:

- Modify bid opening date and time
- Modify specifications of product or service being sought
- Attachment of vendor questions and responses
- Attachment of pre-bid sign-in sheet
- Correction of error
- Other

Description of Modification to Solicitation:

1. Addendum issued to publish Vendor technical questions and Agency answers.

No further changes.

Additional Documentation: Documentation related to this Addendum (if any) has been included herewith as Attachment A and is specifically incorporated herein by reference.

Terms and Conditions:

1. All provisions of the Solicitation and other addenda not modified herein shall remain in full force and effect.
2. Vendor should acknowledge receipt of all addenda issued for this Solicitation by completing an Addendum Acknowledgment, a copy of which is included herewith. Failure to acknowledge addenda may result in bid disqualification. The addendum acknowledgement should be submitted with the bid to expedite document processing.

Attachment A

REQUEST FOR QUOTATION
West Virginia Division of Natural Resources
Cacapon Resort SP – Open End Propane Contract
ARFQ DNR20*32 • Technical Questions

Q1: Can you please provide the current vendor, their pricing, and which OPIS terminal is being used?

A1: Blue Flame, Inc. • \$1.15250 • OPIS terminal is unknown.

Q2: Is the majority of the 155,000 gallons used during the winter season?

A2: Yes.

Q3: Can you please provide specific details as to what the requested maintenance is to entail? Does this include service labor that is charged per month and not per hour? Does this include parts that could be needed?

A3: Vendor installed tanks: include all exterior equipment, labor and parts for maintenance to the facility. Vendor is responsible for delivery of propane to facility. (*Section 3.1.3 & 3.1.3.1*). State owned tanks: includes all exterior equipment (minus the state owned tank), labor and parts for maintenance to the facility. Vendor is responsible for delivery of propane from tank to facility. (*Section 3.2.1 & 3.2.1.1*).

Q4: What is the time frame on switching the tanks out?

A4: Vendor shall set-up and provide service within forty-five (45) days of notice to proceed. (*Section 7.1.1*)

Q5: Can we use 120-gallon vert. tanks in place of the 21 horizontal tanks?

A5: Yes, you may use 120-gallon vertical tanks.

Q6: Can the tanks remain white?

A6: No. Tanks are to be a tan color to match what is in place now. (*Section 3.6.2*)

Q7: Since the vendor is responsible for all equipment from the state owned tanks to the building (*Section 3.2.1*), can we inspect the tank farm equipment prior to bid submission? We would like more information on the vaporizers and other components. Those are owned by the tank farm as well?

A7: Yes, the state owned tanks may be inspected prior to bid submission. (*Tank farm is used in reference to a location at the Park, not a Vendor. See Section 3.2*). The Engineering Section of the Division of Natural Resources has supplied the attached drawings and specifications in reference to the tanks, vaporizers and components.

Q8: Regarding OPIS pricing, we subscribe to the daily average OPIS pricing at Mont Belvieu. Would that be an acceptable index?

A8: Yes.

Q9: On Exhibit A - Pricing Page, did you pull the Estimated OPIS Propane Index Price from a specific terminal, or is that just a place holder to do the math? If you did pull from a terminal, which one?

A9: Number is place holder for bidding purposes only.

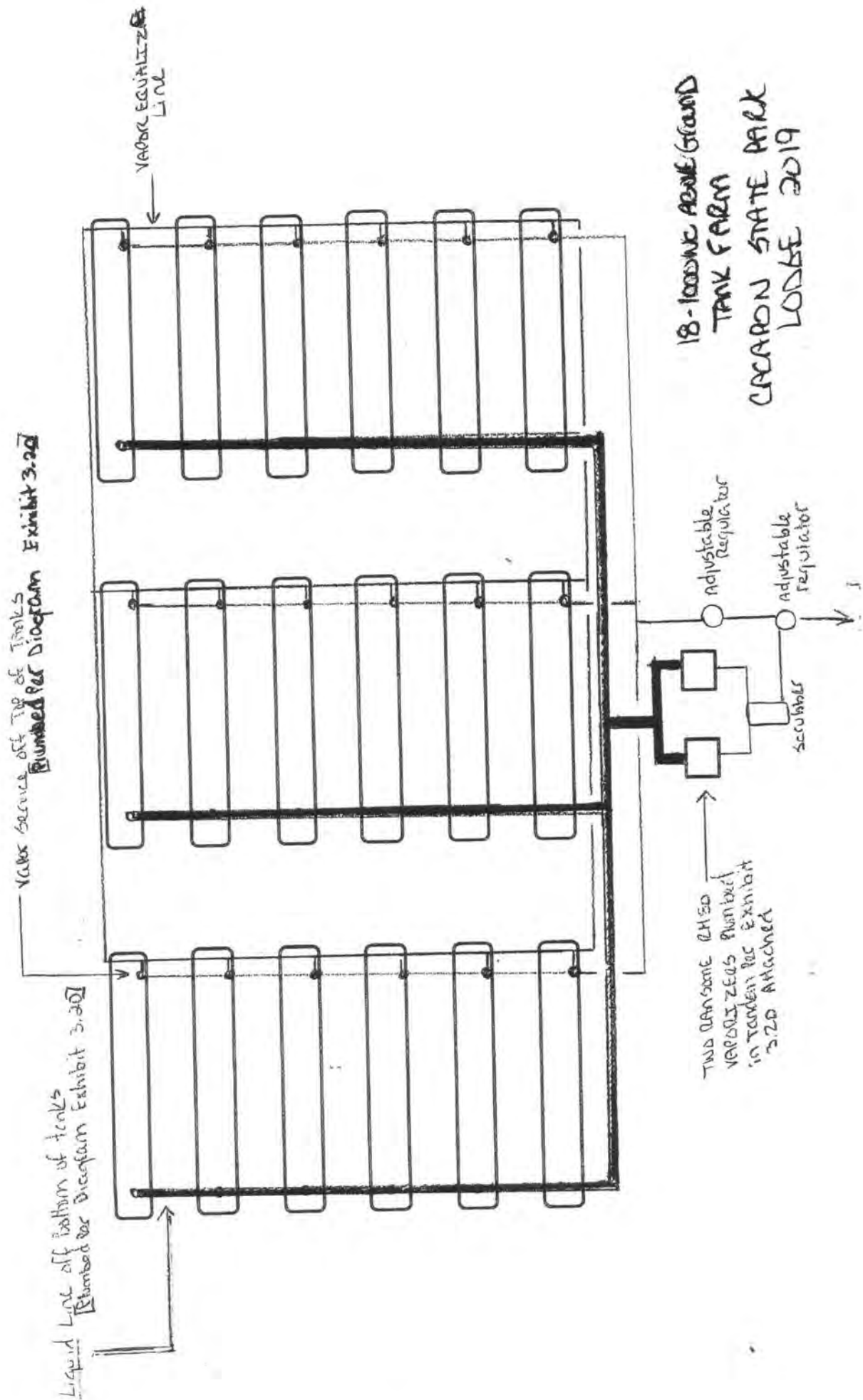

Vapor Service off Top of Tanks
 Rumbered Per Diagram Exhibit 3.20

Liquid Line off Bottom of Tanks
 Rumbered Per Diagram Exhibit 3.20

VAPOR EQUALIZER LINE

18-1000 WINE ABOVE GROUND
 TANK FARM
 CROAPON STATE PARK
 LOSBE 2019

TWO DANSONE Q150
 VAPORIZERS MOUNTED
 IN TANKS PER EXHIBIT
 3.20 ATTACHED

adjustable regulator
 adjustable regulator
 scrubber

EXHIBIT 3.20

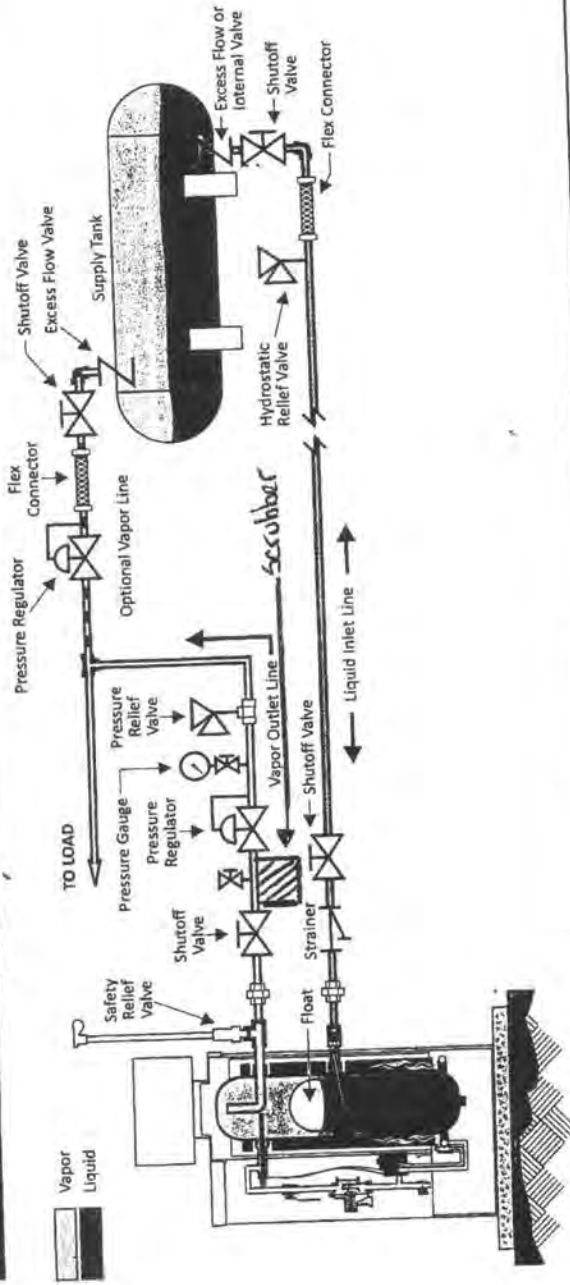

Typical Vaporizer Installation. (Courtesy of Ransome Manufacturing)

RANSOME

MANUFACTURING

Engineering and Equipment Manufacturing

RH Series Direct-Fired LP-Gas Vaporizers



Standard Features

- Mechanical liquid inlet valve provides positive control of LP-Gas liquid level on all RH 50, 80 and RH 120 sizes. Larger sizes use reliable float switch and electric inlet valve to prevent liquid carryover.
- Millivolt-powered gas control system maintains consistent vapor temperature under changing load conditions.
- Gas control valve is located inside the protective dry cabinet with the regulator mounted on the exterior providing for total ventilation.
- Precision operating temperature switch, factory-set and sealed against tampering, incorporates precious metal contacts for extended service life.
- Two-stage pressure regulation provides accurate burner gas burner pressures and performance regardless of changes in inlet pressure.
- ASME code vaporizing tubes with integral heat exchange vanes and insulated ducts provide efficient vaporization with minimum burner input.
- Modular design provides maximum capacity in a compact, rectangular unit.
- Double-Louvered combustion air baffles assure freedom from outages even during adverse weather conditions. (For extreme conditions, optional electric pilot reignitors are available).
- All sizes are capable of infinite turndown and will maintain a ready supply of vapor from zero load to full capacity. At no load, only enough heat will be generated to maintain vapor temperature and to prevent condensation.

Models are available in a complete range of sizes from 50 GPH to 1,000 GPH propane capacity, allowing you to buy precisely the vaporization you need.

Standard models are built to conform with requirements of National Fire Protection Association pamphlet 58.

American Society of Mechanical Engineers Section VIII and California Code of Regulations Title 8. All models are Underwriters Laboratories, Factory Mutual System and Railroad Commission of Texas approved.



**Factory
Mutual
System**

Selection Chart

If your max. propane load requirements are up to *				Height		Width		Depth		Shipping Weight		RANSOME MODEL
GAL/HR	MILLIONS OF BTU/HR	CF/HR	KG/HR	IN.	CM.	IN.	CM.	IN.	CM.	LB.	KG.	
50	4.58	1823	96	31	79	16.5	42	20.5	52	205	92.8	RH50
80	7.32	2916	154	41	104	16.5	42	20.5	52	245	110.9	RH80
120	10.98	4374	231	48.5	123	16.5	42	20.5	52	285	129.1	RH120
200	18.30	7290	384	67.5	171	16.5	42	20.5	52	380	172.1	RH200
400	36.60	14580	768	69.5	177	28	71	26.25	67	920	416.7	RH400
600	54.90	21870	1152	69.5	177	42	107	26.25	67	1380	625.1	RH600
800	73.20	29160	1536	69.5	177	56	142	26.25	67	1840	833.5	RH800
1000	91.50	36450	1920	69.5	177	70	178	26.25	67	2300	1041.9	RH1000

(1) Units may be paralleled to achieve greater capacities. NOTE: For usage with other gases, consult factory for sizing information. (i.e. C3H6, NH3, SO2, C12)

Theory of Operation

The RH Series vaporizer consists of a vertical ASME rated pressure vessel which is directly heated by a gas fired burner. The burner consumes a small portion of vapor from the vessel to develop the heat required for vaporization.

As liquid enters the vessel, it begins to vaporize as heat is absorbed from the warm heat exchanger. This causes the vapor temperature to decrease.

The operating temperature switch monitors vapor temperature and signals the gas control valve to fire the burner when vapor temperature drops below set point (120 degree F).

Ransome Models RH50 thru RH120 use a mechanical liquid level control system that consists of a mechanical inlet valve, which is actuated by a stainless steel ball located inside the vessel. If the liquid level rises above the desired level, the float will lift off the inlet valve lever allowing it to close, preventing a liquid carryover. Once the level drops, the inlet valve will re-open.

Ransome Models RH200 thru RH1000 use an electrically operated liquid level control system which consists of an external float switch and solenoid valve. If the liquid rises above the desired level, the float will close the solenoid valve to prevent a liquid carryover.

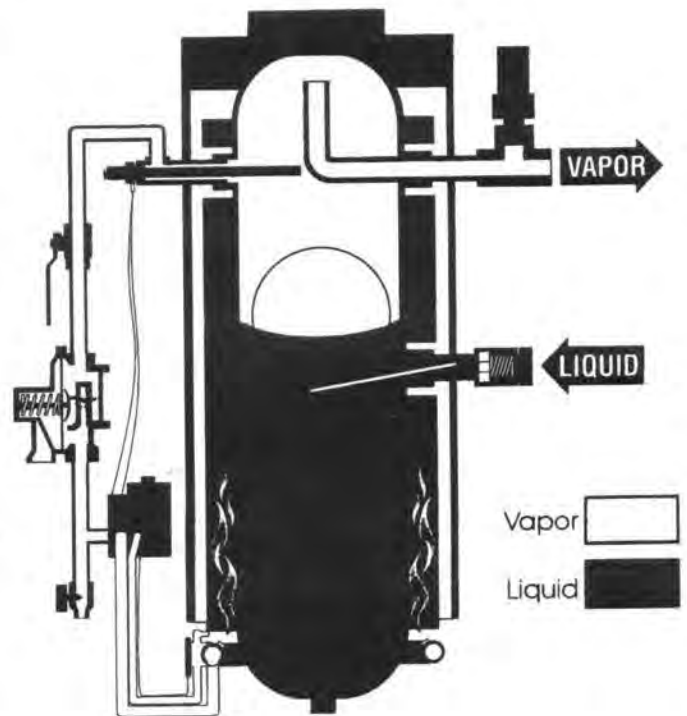

RH Options

Option	Description	Add Suffix
Electric Pilot Reignitor	Protects against pilot outage due to unusually turbulent winds and eliminates need for matches to start vaporizer. 110v. required.	E

Warranty

Ransome Manufacturing, 3495 South Maple Avenue, Fresno, California, warrants to all parties all equipment manufactured and sold by it to be free from defects in material or workmanship under normal use and service when installed and used in accordance with all applicable state and local codes, regulations and laws in accordance with National Fire Protection Pamphlet 58. Ransome Manufacturing agrees to repair or replace any equipment which its examination reveals to have been defective due to faulty workmanship or material, if returned to factory. Transportation charges prepaid. Deviations from recommended applications, system design, installation and service practices, as well as deterioration or wear due to foreign materials or contamination present in LP Gas or air shall be considered as abuses and render this warranty void. This warranty applies for a period of one year from date of installation, but not more than eighteen months after shipment from factory.

This warranty is expressly in lieu of all other warranties expressed or implied, and of all obligations or liabilities on its part for damages, including but not limited to consequential damages, following the use or misuse of equipment sold by it. No agent is authorized to assume any liability for Ransome Manufacturing, except as set forth above.

RANSOME
MANUFACTURING

3495 South Maple Avenue • Fresno, California 93725 • USA
Telephone (559) 485-0979 • Fax (559) 485-8869 • www.ransomeinc.com

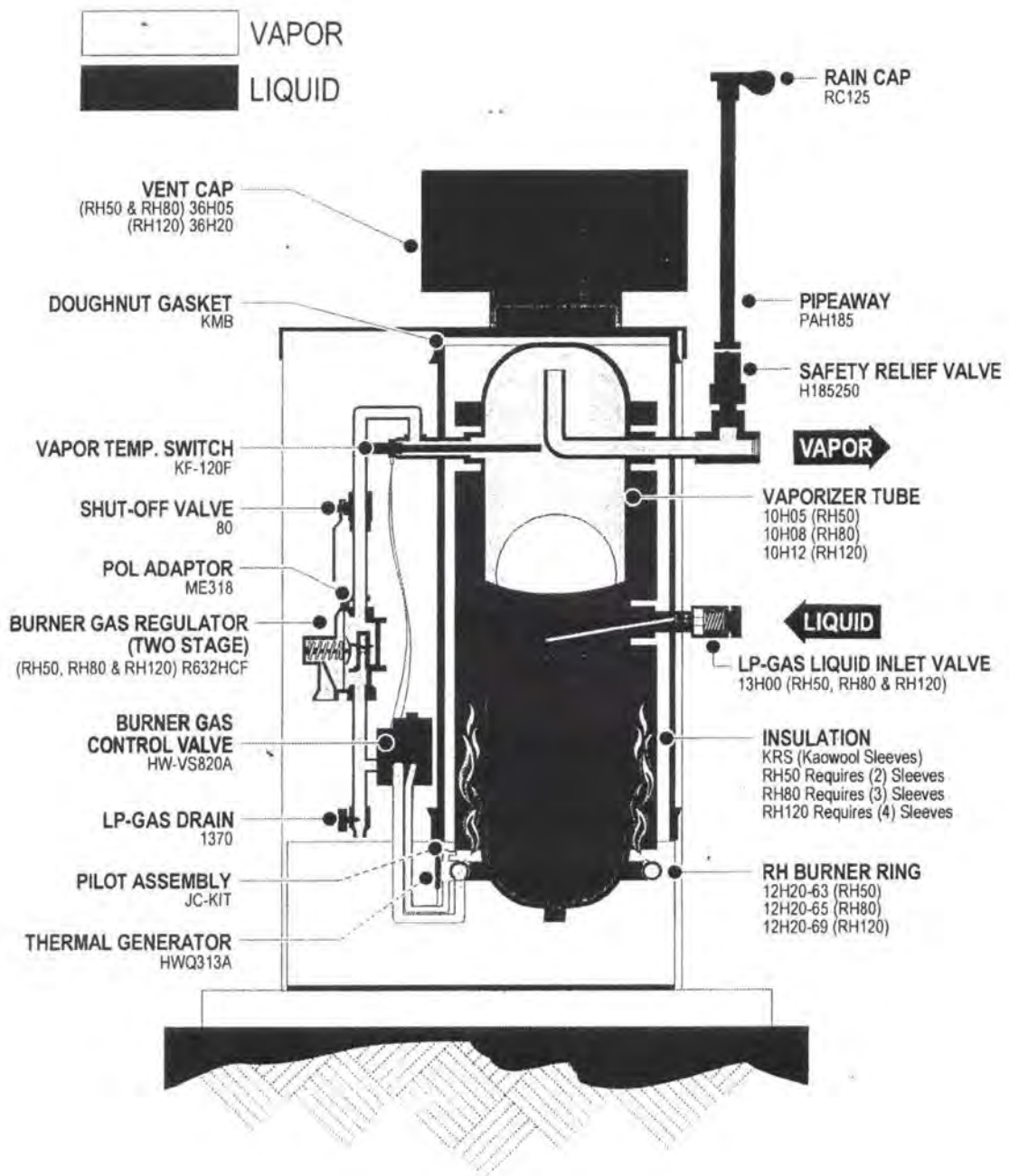

Figure 6-2 --

RH80

Cutaway Drawing

"Y" (WYE) STRAINER ♦ ANSI CLASS 250
CAST IRON ♦ THREADED ENDS

MODEL: YS 12-CI
 (CAST IRON)



3" YS 12-CI

FEATURES

SIZE RANGE : 1/4" ~ 3"

- ◆ **LARGE STRAINING CAPACITY**
 WITH ITS LARGE BODY AND SIZABLE STRAINING ELEMENT, THE YS12 PROVIDES EXCELLENT OPEN AREA RATIOS THAT ARE TYPICALLY TWO-AND-A-HALF TIMES LARGER THAN THE CORRESPONDING PIPELINE.
- ◆ **PRECISION MACHINED SEATS**
 PRECISION MACHINED SCREEN SEATS IN BOTH THE BODY AND CAP HELP TO ENSURE ACCURATE POSITIONING OF THE SCREEN DURING REASSEMBLY AFTER CLEANING. ALSO, THE MACHINED BODY SEATS ENABLE FINER FILTRATION BY PREVENTING DEBRIS BYPASS.
- ◆ **SELF-CLEANING CAPABILITY**
 WITH A TAPPED NPT BLOW-OFF CONNECTION, THIS UNIT CAN BE FITTED WITH A BLOW-DOWN VALVE WHICH FACILITATES CLEANING OF THE STRAINING ELEMENT. PLEASE CONTACT FACTORY FOR MORE INFORMATION.
- ◆ **EPOXY PAINTED**
 ALL UNITS ARE EPOXY PAINTED TO HELP RESIST RUST AND CORROSION.
- ◆ **POTABLE WATER/FDA APPROVED COATINGS AVAILABLE**
 IN ADDITION TO ITS LEAD FREE, CAST IRON BODY, TITAN CAN PROVIDE NSF/ANSI AND FDA APPROVED EPOXY COATINGS WHICH MAKE THIS PRODUCT SUITABLE FOR POTABLE WATER AND FOOD CONTACT APPLICATIONS. NUMEROUS OPTIONS ARE AVAILABLE. PLEASE CONTACT US FOR MORE DETAILS.
- ◆ **THREADED CAP**
 TITAN'S YS12 HAS STRAIGHT THREADS TO PERMIT EASY CAP REMOVAL FOR CLEANING AND PROPER ALIGNMENT WHEN REASSEMBLING STRAINER.
- ◆ **NATURAL GAS AND OTHER SPECIAL APPLICATIONS**
 TITAN HAS EXTENSIVELY TESTED THE YS12 IN GAS APPLICATIONS AND DETERMINED THAT BUNA-N GASKETS PROVIDE SUPERB SEALING CAPABILITIES FOR THE SERVICE. ALWAYS SPECIFY IF A SPECIAL GASKET OR SCREEN IS REQUIRED FOR A SPECIFIC APPLICATION.



Lead Free,
 Cast Iron Body

TECHNICAL

PRESSURE/TEMPERATURE RATING
 CI-ASTM A126 GR. B - CLASS 250
YS 12-CI (THREADED)

WOG (Non-shock): 400 PSI @ 150 °F

* The above listed temperatures are theoretical and may vary during actual operating conditions.

APPLICATIONS

GENERAL APPLICATION: Y-STRAINERS ARE INSTALLED IN A PIPING SYSTEM TO REMOVE UNWANTED DEBRIS FROM THE PIPELINE, PROTECTING EXPENSIVE EQUIPMENT DOWNSTREAM SUCH AS PUMPS, METERS, SPRAY NOZZLES, COMPRESSORS, AND TURBINES. THEY CAN BE PLACED IN A HORIZONTAL OR VERTICAL PIPELINE AS LONG AS THE SCREEN IS IN A DOWNWARD POSITION. STRAINING IS ACCOMPLISHED VIA AN INTERNAL PERFORATED OR MESH LINED STRAINING ELEMENT, THE SIZE OF WHICH SHOULD BE DETERMINED BASED ON THE SIZE OF THE SMALLEST PARTICLE TO BE REMOVED.

The above data represents common market and service applications. No representation or guarantee, expressed or implied, is given due to the numerous variations of concentrations, temperatures and flow conditions that may occur during actual service

"Y" (WYE) STRAINER
YS 12-CI - (Cast Iron)
 Threaded Ends • Cast Iron • ANSI Class 250

ANSI Class
250

BILL OF MATERIALS

No.	PART	YS 12-CI
1	Body ⁽²⁾	Cast Iron A126 Gr. B
2	Cap	Cast Iron A126 Gr. B
3	Straining Element ⁽³⁾	Stainless Steel ⁽⁴⁾
4	Gasket ⁽³⁾⁽⁴⁾	Grafoil
5	NPT Plug (Blow-off) ⁽⁵⁾	Steel

1. Bill of Materials represents standard materials. Equivalent or better materials may be substituted at the manufacturer's discretion.
2. All units are epoxy painted.
3. Denotes recommended spare parts.
4. Contact Titan for special gaskets materials, including Buna-N or Viton, for natural gas, hot air, or other applications.
5. The YS12 can be furnished with bronze blow-off plug to meet Military Specification WW-S-2739. Contact factory.
6. Stainless Steel Straining Element is available in Type 304 and Type 316 Stainless Steel. A wide range of wire mesh and perforated screens are available. See "Standard Screen Selections" chart below for standard perforations and meshes. Please specify if a non-standard screen is required.

Illustrations are representative of a 2" YS12-CI.
Please ask for certified drawings when required.

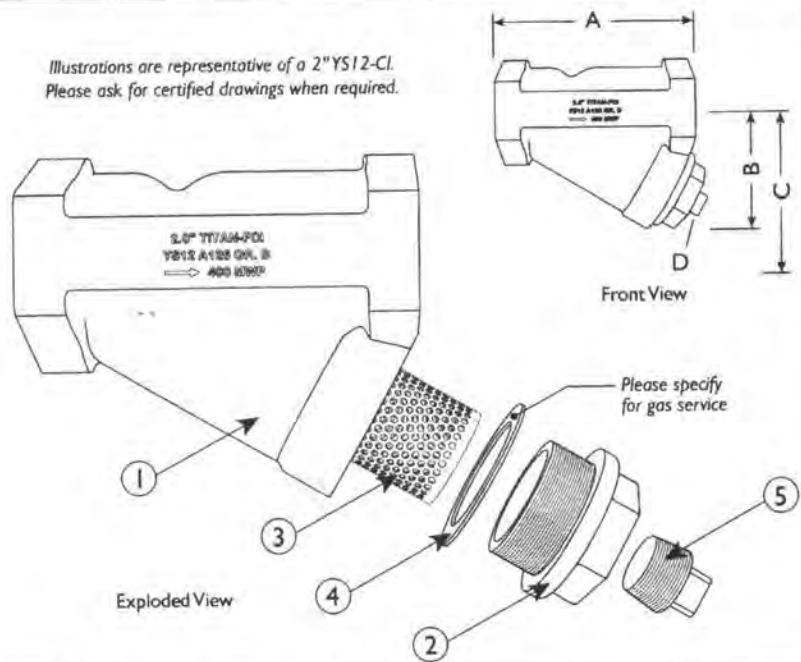

DIMENSIONS AND PERFORMANCE DATA ⁽¹⁾

SIZE	in	1/4	3/8	1/2	3/4	1	1 1/4	1 1/2	2	2 1/2	3
	mm	8	10	15	20	25	32	40	50	65	80
A DIMENSION FACE TO FACE ⁽²⁾	in	3.188	3.188	3.188	3.75	4.2	5.0	5.75	7.0	9.25	10.0
	mm	81	81	81	95	107	127	146	178	235	254
B DIMENSION CENTER LINE TO BOTTOM	in	2.063	2.063	2.063	2.438	2.625	3.375	3.875	4.75	5.875	6.0
	mm	52	52	52	62	67	86	98	121	149	152
C DIMENSION SCREEN REMOVAL	in	2.375	2.375	2.375	3.0	3.25	4.25	5.0	6.125	7.875	8.0
	mm	60	60	60	76	83	108	127	156	200	203
D NPT Plug BLOW-OFF	in	1/4	1/4	1/4	3/8	3/8	3/4	3/4	1	1 1/2	1 1/2
	mm	8	8	8	10	10	20	20	25	40	40
APPROXIMATE ASSEMBLED WEIGHT	lb	1.5	1.5	1.5	2.5	3.5	6.0	9.0	14.0	25.5	32.0
	kg	0.7	0.7	0.7	1.1	1.6	2.7	4.1	6.3	11.6	14.5
Flow Coefficient	C _v	0.7	2	8	15	22	38	42	70	110	160

1. Dimensions and weights are for reference only. When required, request certified drawings.
2. Face to face values have a tolerance of ±0.06 in (±2.0 mm).

PRESSURE - TEMPERATURE RATINGS

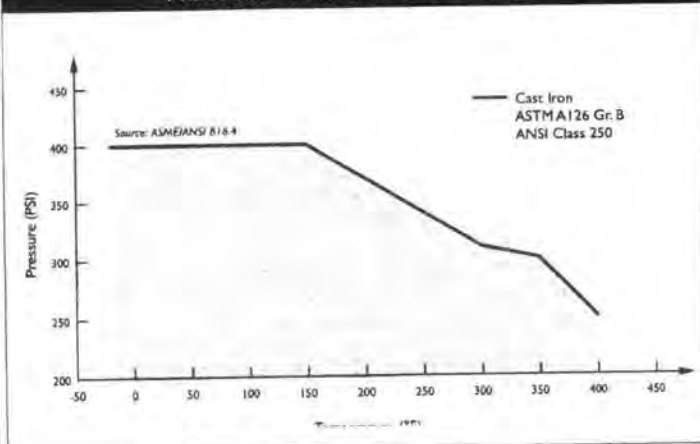

PRESSURE - TEMPERATURE RATING

ANSI Class 250	A126 Gr. B
WOG (Non-shock):	400 PSI @ 150 °F

STANDARD SCREEN SELECTIONS

Size	Liquid	Open Area	Steam	Open Area
1/4" ~ 2"	20 Mesh	51.8%	30 Mesh	44.8%
2 1/2" ~ 3"	1/16 (.0625)	41%	3/64 (.045)	36%

REFERENCED STANDARDS & CODES

CODE	DESCRIPTION
ASME/ANSI B16.4	Cast Iron Threaded Fittings

Item # 3171A, Short Type Hose Coupling for Vapor Service

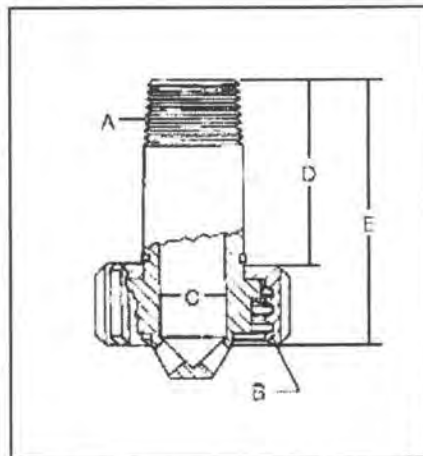

Specifications

Material	Brass
Style	C
A. Hose Connection M. NPT	1/2 in
B. Coupling Connection F. ACME	1-1/4 in

C. Tailpiece Bore	17/32 in
D. Hose End to Nut	1-3/16 in
E. Overall Length	2-7/16 in
Product Type	Short Type Hose Couplings
Manufacturer	RegO

Extra Heavy Pipe Schedule 80 ASTM A 53 Grade A

NPS Designator	DN Designator	Outside Diameter		Inside Diameter		Wall Thickness		Nominal Weight (Mass) per unit Length			
		(Inches)	(mm)	(Inches)	(mm)	(Inches)	(mm)	Plain End (lb/ft)	Plain End (kg/m)	Threads & Couplings (lb/ft)	Threads & Couplings (kg/m)
1/8	6	0.405	10.3	0.215	5.5	0.095	2.41	0.31	0.47	0.32	0.46
1/4	8	0.540	13.7	0.302	7.7	0.119	3.02	0.54	0.80	0.54	0.80
3/8	10	0.675	17.1	0.423	10.7	0.126	3.20	0.74	1.10	0.74	1.10
1/2	15	0.840	21.3	0.549	13.9	0.147	3.73	1.09	1.62	1.09	1.62
3/4	20	1.050	26.7	0.742	18.8	0.154	3.91	1.48	2.20	1.48	2.21
1	25	1.315	33.4	0.957	24.3	0.179	4.55	2.17	3.24	2.19	3.25
1-1/4	32	1.660	42.2	1.278	32.5	0.191	4.85	3.00	4.47	3.03	4.49
1-1/2	40	1.900	48.3	1.500	38.1	0.200	5.08	3.63	5.41	3.65	5.39
2	50	2.375	60.3	1.939	49.3	0.218	5.54	5.03	7.48	5.08	7.55
2-1/2	65	2.875	73.0	2.323	59.0	0.276	7.01	7.67	11.41	7.75	11.52
3	80	3.500	88.9	2.900	73.7	0.300	7.62	10.26	15.27	10.35	15.39
3-1/2	90	4.000	101.6	3.364	85.4	0.318	8.08	12.52	18.63	12.67	18.82
4	100	4.500	114.3	3.826	97.2	0.337	8.56	15.00	22.32	15.20	22.60

Permissible Variations for ASTM A 53 Grades A and B Pipe			
	O.D.	Over	Under
Outside Diameter	NPS 1/8 to 1-1/2 DN 6 to 40	1/64" (0.4mm)	1/64" (0.4mm)
	NPS 2 and up DN 50 and up	1%	1%
Wall Thickness at Any Point		-----	12.5%



ASTM A 53 Grade A Schedule 80 Pipe

ASTM A 53 Grades A and B: Black and Galvanized Pipe is manufactured for ordinary use in steam, water, gas, and air lines. UL Listed and FM Approved, sizes 1" through 6" nominal, for use in Fire Sprinkler Pipe Applications.

Mechanical Properties

Grade A: Yield 30,000 [205 Mpa] psi minimum Tensile: 48,000 psi [330 Mpa] minimum

Grade B: Yield 35,000 [240 Mpa] psi minimum Tensile: 60,000 psi [415 Mpa] minimum

For additional information or to order, contact our pipe department at 800.257.8182.

Fax: 724.346.7260, e-mail info@wheatland.com

Wheatland ASTM A 53 Schedule 40 and Schedule 80 Pipe

Wheatland Steel Pipe is made by specialists who understand that it's the small details that make the difference between average products and superior products. At the Wheatland Plant, most department heads and foremen have been employed in some phase of pipe manufacturing for 25 or more years.

This kind of specialization, experience and knowledge pays off...in workable, threadable, uniform pipe. Delivered clean. Delivered promptly.

Wheatland specializes in manufacturing welded steel pipe in 1/2 through 4 nominal sizes. Available inventory in 1/8 to 12 pipe sizes produced to various ASTM standards is maintained to meet your pipe requirements.

Care, pride and personal concern are bonus features that go into every inch of Wheatland Pipe. Don't settle for less.

Make sure it's quality. Make sure it's Wheatland.

Standard Pipe Schedule 40 ASTM A 53 Grades A and B

NPS Designator	DN Designator	Outside Diameter		Inside Diameter		Wall Thickness		Nominal Weight (Mass) per unit Length			
		(Inches)	(mm)	(Inches)	(mm)	(Inches)	(mm)	Plain End (lb/ft)	Plain End (kg/m)	Threads & Couplings (lb/ft)	Threads & Couplings (kg/m)
1/8	6	0.405	10.3	0.269	6.8	0.068	1.73	0.24	0.37	0.25	0.37
1/4	8	0.540	13.7	0.364	9.2	0.088	2.24	0.43	0.63	0.43	0.63
3/8	10	0.675	17.1	0.493	12.5	0.091	2.31	0.57	0.84	0.57	0.84
1/2	15	0.840	21.3	0.622	15.8	0.109	2.77	0.85	1.27	0.86	1.27
3/4	20	1.050	26.7	0.824	20.9	0.113	2.87	1.13	1.69	1.14	1.69
1	25	1.315	33.4	1.049	26.6	0.133	3.38	1.68	2.50	1.69	2.50
1-1/4	32	1.660	42.2	1.380	35.1	0.140	3.56	2.27	3.39	2.28	3.40
1-1/2	40	1.900	48.3	1.610	40.9	0.145	3.68	2.72	4.05	2.74	4.04
2	50	2.375	60.3	2.067	52.5	0.154	3.91	3.66	5.44	3.68	5.46
2-1/2	65	2.875	73.0	2.469	62.7	0.203	5.16	5.80	8.63	5.85	8.67
3	80	3.500	88.9	3.068	77.9	0.216	5.49	7.58	11.29	7.68	11.35
3-1/2	90	4.000	101.6	3.548	90.1	0.226	5.74	9.12	13.57	9.27	13.71
4	100	4.500	114.3	4.026	102.3	0.237	6.02	10.80	16.07	10.92	16.23
5	125	5.563	141.3	5.047	158.2	0.258	6.55	14.63	21.77	14.90	22.07
6	150	6.625	168.3	6.065	154.1	0.280	7.11	18.99	28.26	19.34	28.58
8	200	8.625	219.1	7.981	202.7	0.322	8.18	28.58	42.55	29.35	43.73
10	250	10.750	273.0	10.020	254.5	0.365	9.27	40.52	60.29	41.49	63.36
Standard Pipe											
12'	300	12.750	323.8	12.000	304.8	0.375	9.52	49.61	73.78	51.28	76.21

Note: NPS 12 dimensions are for standard wall pipe, not schedule 40.

Product Type and Specification:

Standard welded pipe is produced in 1/2 to 6 trade sizes. Wheatland pipe is produced to ASTM A 53 Grades A and B, A 501, and A 589 Type II, API 5L and Federal Specification WW-P404. All pipe threads conform to ANSI B1.20.1. Merchant couplings comply with ASTM A 865.

Specifications and descriptions are accurate as known at time of publication and subject to change without notice.

A 53 Grades A & B Schedule 40 Pipe

General Service



Dial Divisions	General Service 3/2/3% of Span		
Ranges	Figure Intervals	Minor Graduations	
Vacuum	5	1	
COMPOUND			
30" Hg VAC to 15 psi	10 5	2	1
30" Hg VAC to 30 psi	10 10	2	1
30" Hg VAC to 60 psi	10 10	2	2
30" Hg VAC to 150 psi	30 30	5	5
30" Hg VAC to 300 psi	30 50	- 10	
PRESSURE			
0 to 15 psi	3	0.2	
0 to 30 psi	5	1	
0 to 60 psi	10	1	
0 to 100 psi	10	2	
0 to 160 psi	20	2	
0 to 200 psi	50	4	
0 to 300 psi	50	5	
0 to 400 psi	50	5	
0 to 600 psi	50	10	
HIGH PRESSURE			
0 to 1,000 psi	200	20	
0 to 1,500 psi	300	20	
0 to 2,000 psi	400	40	
0 to 3,000 psi	500	100	
0 to 4,000 psi	1,000	100	
0 to 5,000 psi	1,000	100	

GENERAL SERVICE GAUGE OPTIONS			
OPTION	TYPE	SUFFIX	AVAILABLE ON MODELS
Restrictors	Add restrictor	H	All models - Consult factory for other sizes
Catalog Dials	psi only	E	See Marsh Price List for minimums
	bar only	L1	
	kg/cm ² only	L2	
	kPa only	L3	
	MPa only	L4	
	psi & bar	W1	
	psi & kg/cm ²	W2	
	psi & MPa	W4	
Custom Dials	Custom face	M	See Marsh Price List for minimums
Window	Instrument glass w/ring (GS)	F1	1½" - 3½" Consult factory for availability
	Acrylic	F2	4½" Consult factory for availability
Pointer	Adjustable (slotted) pointer (AD)	Z1	2" - 4½" Consult factory for availability
	Max. Hand Assembly (MX)	Z2	2" - 3½" CB or LM only, Consult factory for availability
Cases	3 hole front flange (FF)		1½" - 3½" See below for part number
	Part Numbers: 1½" x ½" (J07XX), 2" x ½" (J25XX), 2" x ¼" (J29XX), 2½" x ½" (J61XX), 2½" x ¼" (J63XX), 3½" x ½" (J85XX), 3½" x ¼" (J89XX). Consult factory for availability.		
Rings	Friction ring (external), black (FB)	A2	1½" to 3½" CB or LM only
Special Connections			Consult Factory for availability



(J90XX Only)

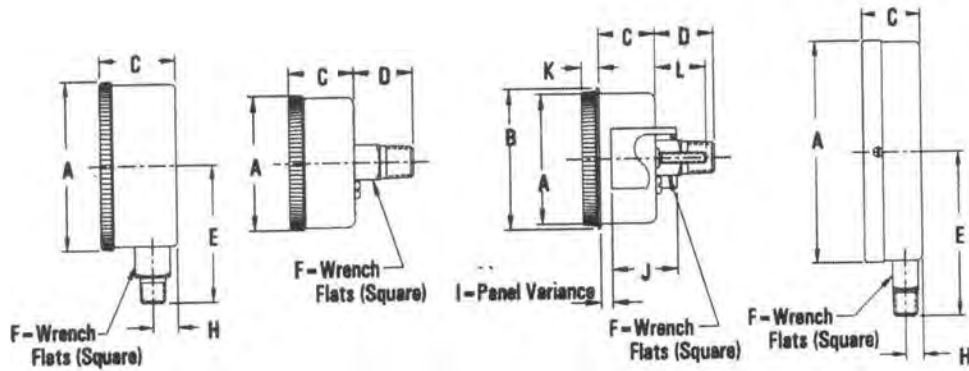

ALL DIMENSIONS ARE NOMINAL

GENERAL SERVICE CASE DIMENSIONS

Part#	Dial Size	Mount	A	B	C	D	E	F	H	I	J	K	L
J04xx	1½	¼" LM	1.67		.90		1.50	⅜"	.26				
J05xx	1½	¼" UC	1.60	1.75	.71	.72		⅜"		.06-.37	.81	.19	.63
J06xx	1½	¼" CB	1.67		.90	.72		⅜"					
J11xx	2.0	¼" LM	2.20		1.22		1.82	⅜"	.40				
J14xx	2.0	¼" LM	2.20		1.22		1.82	⅜"	.40				
J18xx	2.0	¼" CB	2.20		1.22	.82		⅜"					
J20xx	2.0	¼" CB	2.20		1.22	.82		⅜"					
J24xx	2.0	¼" UC	2.06	2.25	.94	.88		⅜"		0-0.43	1.22	.20	.92
J26xx	2.0	¼" UC	2.06	2.25	.94	.88		⅜"		0-0.43	1.22	.20	.92
J40xx	2½	¼" LM	2.73		1.22		2.10	⅜"	.40				
J46xx	2½	¼" LM	2.73		1.22		2.10	⅜"	.40				
J50xx	2½	¼" CB	2.73		1.23	.82		⅜"					
J54xx	2½	¼" CB	2.73		1.23	.82		⅜"					
J60xx	2½	¼" UC	2.58	2.81	.94	.88		⅜"		0-0.43	1.22	.20	.92
J62xx	2½	¼" UC	2.58	2.81	.94	.88		⅜"		0-0.43	1.22	.20	.92
J80xx	3½	¼" LM	3.71		1.22		2.77	⅜"	.40				
J86xx	3½	¼" CB	3.71		1.15	.80		⅜"					
J88xx	3½	¼" UC	3.65	3.98	.91	.87		⅜"		0-0.49	1.10	.24	.92
J90xx	4½	¼" LM	4.53		1.22		3.16	⅜"	.40				

General Service



SPECIFICATIONS

ACCURACY

ASME Grade B- $\pm 3/2/3\%$ ($\pm 2\%$ of range across middle half of scale)

CASE SIZES

1 1/2", 2", 2 1/2", 3", 4" diameter

CASE MATERIAL

Steel, black painted

CASE STYLE

CB - Center Back Mount

LM - Lower Mount

UC - U-Clamp Mount

See option tables for Front Flange

TUBE & SOCKET

Copper alloy

MOVEMENT

Brass

CONNECTION

1/2" & 3/4" NPT

RANGES

0 to 30" Hg VAC; Compound 30" Hg vac to 400 psi; 15 to 5,000 psi

DIAL STANDARD

Dual scale psi and kPa

DIAL COLOR

Black markings on white

POINTER

Aluminum, black painted

WINDOW

1 1/2", 2", 2 1/2", 3": acrylic, twist-in Clearlok

4": flat glass window with steel friction ring

RESTRICTOR

Standard for ranges 1,000 psi and above

WEIGHT

1-1/2"	0.2 lb.
2"	0.3 lb.
2-1/2"	0.4 lb.
3-1/2"	0.5 lb.
4-1/2"	0.75 lb.

GENERAL SERVICE GAUGE

- Dial Sizes: 1 1/2", 2", 2 1/2", 3" & 4"
- Superb quality, economical price
- Pressure ranges to 5000 psi

Marsh Instruments General Service Steel Case Gauges are an economical, general purpose gauge for pressure measurement from vacuum/compound through 5,000 psi. Suited for use with water, oil, air, gas, or other non-corrosive media.

Typical applications include FRLs, compressors, pumps, boilers, regulators, dryers as well as commercial and industrial equipment.

STANDARD RANGES & PART NUMBERS

GENERAL SERVICE GAUGES							
TYPE	1 1/2"			2"			
Size	Steel			Steel			
Case Material	Copper Alloy			Copper Alloy			
Internals	LM	UC	CB	LM	LM	CB	CB
Mounting / Case Style	1/2" NPT	1/2" NPT	1/2" NPT	1/2" NPT	1/2" NPT	1/2" NPT	1/2" NPT
Connection	psi/kPa			psi/kPa			
Scale Standard	J0405	J0505	J0605	J1105	J1405	J1805	J2005
0 to 30" Hg VAC	J0410	J0510	J0610	J1110	J1410	J1810	J2010
30" Hg VAC to 15 psi	J0412	J0512	J0612	J1112	J1412	J1812	J2012
30" Hg VAC to 30 psi	J0414	J0514	J0614	J1114	J1414	J1814	J2014
30" Hg VAC to 60 psi	J0418	J0518	J0618	J1118	J1418	J1818	J2018
30" Hg VAC to 100 psi	J0418	J0518	J0618	J1118	J1418	J1818	J2018
30" Hg VAC to 150 psi	J0420	J0520	J0620	J1120	J1420	J1820	J2020
30" Hg VAC to 200 psi	J0420	J0520	J0620	J1120	J1420	J1820	J2020
30" Hg VAC to 300 psi	J0424	J0524	J0624	J1124	J1424	J1824	J2024
30" Hg VAC to 400 psi				J1126	J1426	J1826	J2026
0 to 15 psi	J0440	J0540	J0640	J1140	J1440	J1840	J2040
0 to 30 psi	J0442	J0542	J0642	J1142	J1442	J1842	J2042
0 to 60 psi	J0446	J0546	J0646	J1146	J1446	J1846	J2046
0 to 100 psi	J0448	J0548	J0648	J1148	J1448	J1848	J2048
0 to 160 psi	J0452	J0552	J0652	J1152	J1452	J1852	J2052
0 to 200 psi	J0454	J0554	J0654	J1154	J1454	J1854	J2054
0 to 300 psi	J0458	J0558	J0658	J1158	J1458	J1858	J2058
0 to 400 psi	J0460	J0560	J0660	J1160	J1460	J1860	J2060
0 to 600 psi	J0464	J0564	J0664	J1164	J1464	J1864	J2064
0 to 1,000 psi	J0472	J0572	J0672	J1172	J1472	J1872	J2072
0 to 1,500 psi	J0474	J0574	J0674	J1174	J1474	J1874	J2074
0 to 2,000 psi	J0476	J0576	J0676	J1176	J1476	J1876	J2076
0 to 3,000 psi	J0478	J0578	J0678	J1178	J1478	J1878	J2078
0 to 5,000 psi	J0482	J0582	J0682	J1182	J1482	J1882	J2082

NOTE: Items are available on special order. However, minimums and lead times apply. Consult factory.



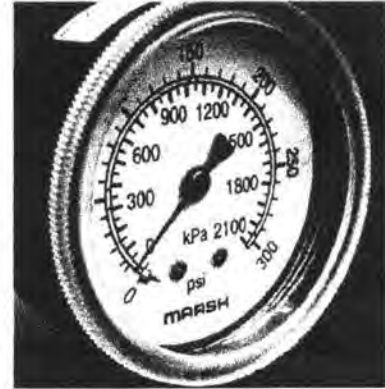
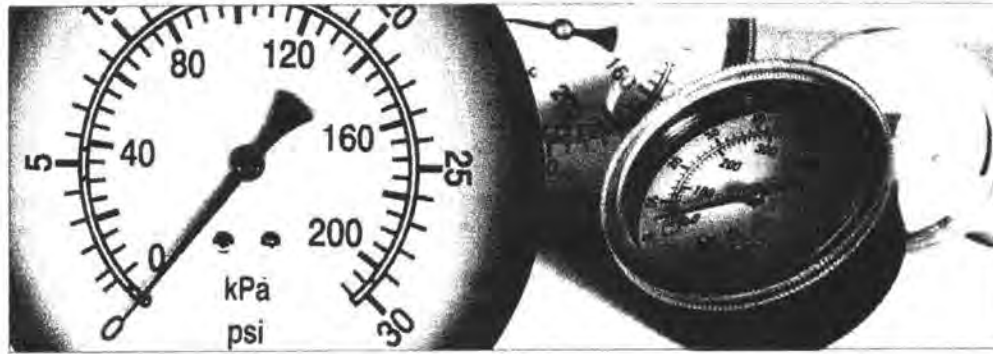

STANDARD RANGES & PART NUMBERS

GENERAL SERVICE GAUGES													
TYPE	2"		2 1/2"						3 1/2"			4 1/2"	
Size	Steel		Steel						Steel			Steel	
Case Material	Copper Alloy		Copper Alloy						Copper Alloy			Copper Alloy	
Internals	UC	UC	LM	LM	CB	CB	UC	UC	LM	CB	UC	LM	
Mounting / Case Style	1/2 NPT	1/2 NPT	1/2 NPT	1/2 NPT	1/2 NPT	1/2 NPT	1/2 NPT	1/2 NPT	1/2 NPT	1/2 NPT	1/2 NPT	1/2 NPT	
Connection	psi/kPa		psi/kPa						psi/kPa			psi/kPa	
Scale Standard	psi/kPa		psi/kPa						psi/kPa			psi/kPa	
0 to 30" Hg VAC	J2405	J2605	J4005	J4605	J5005	J5405	J6005	J6205	J8005	J8605	J8805	J9005	
30" Hg VAC to 15 psi	J2410	J2610	J4010	J4610	J5010	J5410	J6010	J6210	J8010	J8610	J8810	J9010	
30" Hg VAC to 30 psi	J2412	J2612	J4012	J4612	J5012	J5412	J6012	J6212	J8012	J8612	J8812	J9012	
30" Hg VAC to 60 psi	J2414	J2614	J4014	J4614	J5014	J5414	J6014	J6214	J8014	J8614	J8814	J9014	
30" Hg VAC to 100 psi	J2416	J2616	J4016	J4616	J5016	J5416	J6016	J6216	J8016	J8616	J8816	J9016	
30" Hg VAC to 150 psi	J2418	J2618	J4018	J4618	J5018	J5418	J6018	J6218	J8018	J8618	J8818	J9018	
30" Hg VAC to 200 psi	J2420	J2620	J4020	J4620	J5020	J5420	J6020	J6220	J8020	J8620	J8820	J9020	
30" Hg VAC to 300 psi	J2424	J2624	J4024	J4624	J5024	J5424	J6024	J6224	J8024	J8624	J8824	J9024	
30" Hg VAC to 400 psi	J2426	J2626	J4026	J4626	J5026	J5426	J6026	J6226	J8026	J8626	J8826	J9026	
0 to 15 psi	J2440	J2640	J4040	J4640		J5440		J6240	J8040	J8640	J8840	J9040	
0 to 30 psi	J2442	J2642	J4042	J4642	J5042	J5442	J6042	J6242	J8042	J8642	J8842	J9042	
0 to 60 psi	J2446	J2646	J4046	J4646	J5046	J5446	J6046	J6246	J8046	J8646	J8846	J9046	
0 to 100 psi	J2448	J2648	J4048	J4648	J5048	J5448	J6048	J6248	J8048	J8648	J8848	J9048	
0 to 180 psi	J2452	J2652	J4052	J4652	J5052	J5452	J6052	J6252	J8052	J8652	J8852	J9052	
0 to 200 psi	J2454	J2654	J4054	J4654	J5054	J5454	J6054	J6254	J8054	J8654	J8854	J9054	
0 to 300 psi	J2458	J2658	J4058	J4658	J5058	J5458	J6058	J6258	J8058	J8658	J8858	J9058	
0 to 400 psi	J2460	J2660	J4060	J4660	J5060	J5460	J6060	J6260	J8060	J8660	J8860	J9060	
0 to 600 psi	J2464	J2664	J4064	J4664	J5064	J5464	J6064	J6264	J8064	J8664	J8864	J9064	
0 to 1,000 psi	J2472	J2672	J4072	J4672	J5072	J5472	J6072	J6272	J8072	J8672	J8872	J9072	
0 to 1,500 psi	J2474	J2674	J4074	J4674	J5074	J5474	J6074	J6274	J8074	J8674	J8874	J9074	
0 to 2,000 psi	J2476	J2676	J4076	J4676	J5076	J5476	J6076	J6276	J8076	J8676	J8876	J9076	
0 to 3,000 psi	J2478	J2678	J4078	J4678	J5078	J5478	J6078	J6278	J8078	J8678	J8878	J9078	
0 to 5,000 psi	J2482	J2682	J4082	J4682	J5082	J5482	J6082	J6282	J8082	J8682	J8882	J9082	

NOTE: Items are available on special order. However, minimums and lead times apply. Consult factory.

Rego Internal Valves & Assemblies

1 1/4" Threaded Internal Valve for Small Capacity Pumping Systems and Bobtail Vapor Equalization

Designed primarily for use with LP-Gas and anhydrous ammonia as a main valve on small capacity pumping systems, NH₃ nurse tanks and in-line installations. It may also be installed in the vapor equalizing opening on bobtail delivery trucks. Installation is quick and easy, and it fits in both full and half couplings, as well as, in-line applications. The valve may be actuated manually by hand or cable.



Part Number	Inlet Connection (NPT)	Outlet Connection (NPT)	Closing Flow (10 PSI)		LP-Gas Vapor Capacity (150 PSI)		Actuator	
			LP-Gas	NH ₃	2 1/2" IC	1 1/2" IC	None	Optional
A3209D050	1 1/4"	1 1/4"	50	45	13,300	22,900	A3209TL	A3209PA
A3209D080	1 1/4"	1 1/4"	80	72	15,700	26,700	A3209TL	A3209PA
A3209DT050	1 1/4"	1 1/4"	50	45	13,300	22,900	A3209TL	A3209PA
A3209DT080	1 1/4"	1 1/4"	80	72	15,700	26,700	A3209TL	A3209PA

* Installs in full or half coupling.
** Data for flow in half coupling.

New A3209PAF Actuator

This actuator permits the A3209 internal valve to be opened and closed remotely. It can be used with the air brake system on a bobtail, or can be used at a dispenser or bulk plant.



Part No.	Minimum Operating Pressure	Maximum Operating Pressure
A3209PAF	40 PSIG	125 PSIG

1 1/4" Threaded Angle Internal Valve for Motor Fuel Dispensers and Small Capacity Pumping Systems

Designed primarily for use with LP-Gas and anhydrous ammonia as a main valve on pump systems with small capacity, such as motor fuel dispensers. It may also be installed in bottom liquid withdrawal openings in NH₃ nurse tanks or the vapor equalizing opening of bobtail delivery trucks. Installation is quick and easy, and must be installed in a modified half coupling or the equivalent. The valve may be actuated manually by cable or pneumatically.

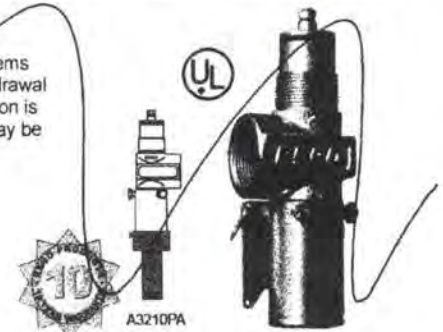

Part Number	Inlet Connection	Outlet Connection	Closing Flow (10 PSI)		LP-Gas Vapor Capacity (150 PSI)				Actuator
			LP-Gas	NH ₃	1 1/2" IC	1" IC	75 PSIG	100 PSIG	
A3210A065	1 1/4"	1 1/4"	65	58.5	17,000	22,250	26,500	30,000	A3210PA-R1

For use in half coupling only, 1 1/2" diameter minimum bore. If welded-in dip pipe is required, use of 1 1/2" schedule 40 pipe is recommended -flow will be reduced by approximately 10%.

Item # 3139-38, Vapor Relief Valves (3139 Series)

Designed for use as a relief valve on first stage regulators that comply with the NFPA 58 2.5.7.5 exception: "first stage regulators with a rated capacity of more than 500,000 BTU/hr. shall be permitted to have a separate relief valve."

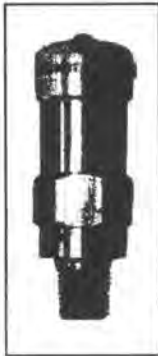

Features | Specifications

Features

- Pop-action design keeps product loss to a minimum.
- Suitable for use downstream of 1580 series regulators on vapor systems to comply with NFPA 58.
- May be installed on either the regulator pressure gauge port or on a fitting downstream from the regulator outlet.
- Constructed of non-corrosive brass.

Specifications

Set Pressure

38 psig

Regulator Settings	20 psig
Connection Size	1/4" M. NPT
Height	2-27/32 in
Width	1-1/16 in
Flow Capacity at 120 % of Set Pressure (SCFH Propane)	2304 (Flow recorded at 45.6 PSI inlet pressure.)
Product Type	Vapor Relief Valves
Manufacturer	RegO

Item # A3209D080, 1 1/4" Threaded Internal Valve for Small Capacity Pumping Systems and Bobtail Vapor Equalization (A3209D & A3209DT Series)

Designed primarily for use with LP-Gas and anhydrous ammonia as a main valve on small capacity pumping systems, NH₃ nurse tanks and in-line installations. It may also be installed in the vapor equalizing opening on bobtail delivery trucks. Installation is quick and easy, and it fits in both full and half couplings, as well as, in-line applications. The valve may be actuated manually by hand or cable.

Seat disc fully retained and field replaceable

Cam attached with Allen head fastener which is

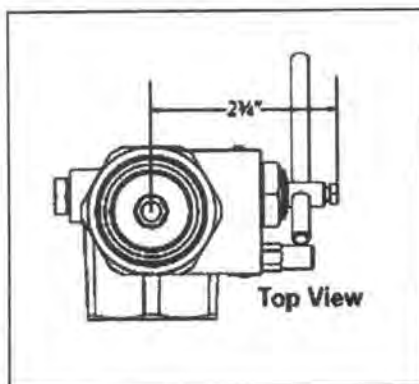

[+ more](#)

[Features](#) | [Materials](#) | [Specifications](#) | [Note](#)

Features

- Valve is compact, with one piece body construction.
- Spring loaded V-packing with heavy duty wiper ring on operating shaft for dependable leak-free

construction.

- Nylon bearing supported operating shaft provides smooth, easy operation.
- Simple operating lever allows for easy connection of cable controls.
- Built in excess flow valve
- Return spring forces the valve to the closed position when the lever is released.
- All critical operating components are located in the valve body and inside the container coupling for maximum protection against damage.
- Midway stem position allows for quick pressure equalization.
- Equipped with 212° F, UL listed fuse link for thermal protection.

Materials

Body Material	Ductile Iron
Operating Lever Material	Cadmium Plated Carbon Steel
Stem Material	Stainless Steel
Springs Material	Stainless Steel
Seat Disc Material	Resilient Synthetic Rubber
Shaft Bearing Material	Nylon

Specifications

Series	A3209D
Inlet Connection M. NPT	1-1/4 in
Outlet Connection F. NPT	1-1/4 in
Closing Flow (LP-Gas)	80 gpm
Closing Flow (NH ₃)	72 gpm
LP-Gas Vapor Capacity at 25 psig	15700 SCFH/Propane
LP-Gas Vapor Capacity at 100 psig	26700 SCFH/Propane
Accessories Thermal Latch	A3209TL

Accessories Pneumatic Actuator	A3209PA A3209PAF
Product Type	1 1/4" Threaded Internal Valve
Manufacturer	RegO

Note

Multiply flow rate by 0.94 to determine liquid butane capacity and by 0.90 to determine liquid anhydrous ammonia capacity.

[All Categories](#) > [Pressure Regulator](#) > [High Pressure Regulators](#) > [High Pressure Industrial / Commercial Pounds-to-Pounds Regulators \(1580M and AA1580M Series\)](#) > Item # 1588VL

Item # 1588VL, High Pressure Industrial / Commercial Pounds-to-Pounds Regulators (1580M and AA1580M Series)

Designed to reduce LP-Gas and anhydrous ammonia container pressures to between 3 and 125 PSIG. Precision-built with a multimillion BTU capacity, the 1580M series is perfect for such big, tough jobs as crop dryers, asphalt batch mixing plants, road building "tar wagons", heat treating and other large industrial and commercial loads. It's also ideal as a first stage regulator in large multiple operations. The AA1580M series is ideal for use in anhydrous ammonia applications such as blue print

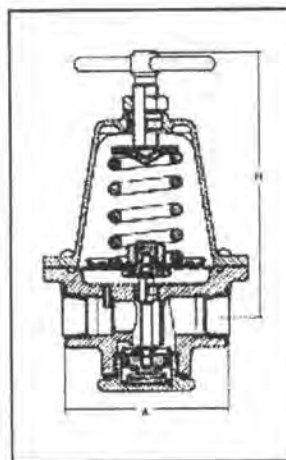

[more](#)

[Features](#) | [Materials](#) | [Specifications](#) | [Note](#)

Features

- Large nozzle and straight through flow provides high capacity and resistance to freeze-up.
- O-ring on retainer assembly provides a dampening effect to reduce vibration.
- Suitable for both liquid and vapor service.
- Can be readily fitted with pressure gauge in 1/4" F. NPT port.

Materials

Body Material	Forged Aluminum
Bonnet Material	Die Cast Aluminum
Spring Material	Steel
Valve Seat Disc Material	Resilient Rubber
Diaphragm Material	Integrated Fabric Synthetic Rubber

Specifications

Service	LP-Gas
Adjustment Method	Tee Handle
Inlet & Outlet Connections	1" F. NPT
Recommended Delivery Pressure Range	25 to 50 psig
A. Width	3-1/2 in
B. Height (Max.)	7 in

Capacity Determined at Set Pressure	30 psig
Capacity	12000000 CFH/NH ₃
Product Type	High Pressure Industrial / Commercial Pounds-to-Pounds Regulators
Manufacturer	RegO

Note

Care must be taken to prevent re-liquification of propane at normal temperatures by heat tracing or other effective means. Use of a relief valve upstream or downstream of these regulators is recommended in accordance with NFPA 58.

Excess Flow Valve for DOT Cylinders 3199W

Application

Designed for use on portable systems with vapor or liquid including torches, heaters, lead melting burners, tar and asphalt burners, wallpaper steamers and other applications involving portable DOT cylinders. The POL inlet attaches directly to the cylinder valve and the outlet mounts to the regulator.

Features

- Integral ball check design.
- Machined groove designed to break-off and allow excess flow valve ball to close.

Materials

Body.....	Brass
Nut.....	Brass
Bell.....	Stainless Steel
Spring.....	Stainless Steel
Retainer Spring.....	Stainless Steel
Retainer.....	Brass



3199W

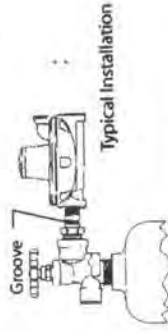
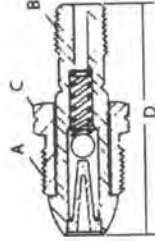

Typical Installation



NOTE:
No protection is afforded should break-off occur downstream of the groove. Also, restrictions introduced by the regulator may prevent closing of the valve due to limited flow capacity. The valve's purpose is to protect the cylinder valve outlet should the regulator be broken off of its connection (at the groove), in which case it will close. It must not be depended upon to protect against breaks downstream of the regulator.

Ordering Information

Part Number	A.		B.	C.	D.	Approximate Closing Flow*		
	Inlet Connection	Outlet Connection				Effective Length (Approx.)	Liquid (GPM/Propane)	Vapor SCFH (Propane)
3199W	Male POL	1/4"	1/4"	7/8"	2 7/8"	.95	265	500

* Based on horizontal installation of excess flow valve. Flows are slightly more when valves are installed with outlet up, slightly less when installed with outlet down.
NOTE: Multiply flow rate by .94 to determine liquid butane flow.

T-100NE

System-6® Super Ball- Valve



ISO EN 9001:2000



T-100NE

Description

System 6® SuperBall™ - 1/4 turn, lever operated, hot forged brass ball valve. 100% full port. Blow-out proof two-piece design. Made in Italy. 100% tested.

Features

- 2 Viton® Stem O-rings
- Hostafflon® TFM-1600 Packing and Seats
- Ecological washed
- Solid TEA coated brass ball
- 100% Full Port

Approvals

- UL Listed VQGU, MHKZ, YQNZ, YRBX, YRPV, YSDT, UL 842
- FM approval
- CSA Certified
- Delta C
- NSF 61-8 Certified (1/4" - 2") - tested at 180° F (commercial hot water)
- NPT connections

Accessories

- "Lift-N-Lock" locking device
- 2" Handle extension
- Lever and Round 304 stainless steel handles
- "Slo-Ball" Handle (for metering under high pressures)
- Red Painted Aluminum "T" Handle
- Pneumatic & Electric Actuation Available upon request

Warranty

The Company, for a period of one year from the date of shipment, warrants each product or system of its own manufacture to the original purchaser to be free from defects in material and workmanship under normal use, service and maintenance.

Architect/Engineer approval

Job Name _____ Date _____
Model Specified _____ Quantity _____
Variations Specified _____
Customer/Wholesaler _____
Contractor _____
Architect _____

Note: Information subject to change without notice.

T-100NE

System-6[®] Super Ball- Valve

Description

System 6[®] SuperBall™ - 1/4 turn, lever operated, hot forged brass ball valve. 100% full port. Blow-out proof two-piece design. Made in Italy. 100% tested.

Dimensions in Inches

Computer No.	Valve Size	A	B	C	D	E	CV†
100-701	1/4"	1.81	0.91	1.41	0.39	2.95	11.84
100-702	3/8"	1.85	0.93	1.41	0.39	2.95	11.84
100-703	1/2"	2.48	1.24	1.53	0.59	2.95	20.25
100-704	3/4"	2.71	1.36	1.93	0.79	3.74	41.83
100-705	1"	3.30	1.65	2.40	1.00	4.72	78.38
100-706	1-1/4"	3.78	1.89	2.59	1.25	4.72	132.10
100-707	1-1/2"	4.17	2.09	3.22	1.57	5.90	206.96
100-708	2"	5.00	2.50	3.50	2.00	5.90	346.00
100-709	2-1/2"	6.06	3.03	4.72	2.48	2.50	484.39
100-710	3"	7.08	3.54	5.31	2.99	3.00	638.50
100-711	4"	8.66	4.33	5.90	3.93	4.00	1092.00

† The CV Factor is the gallons of water per minute passed through the valve with a 1 PSI pressure drop.

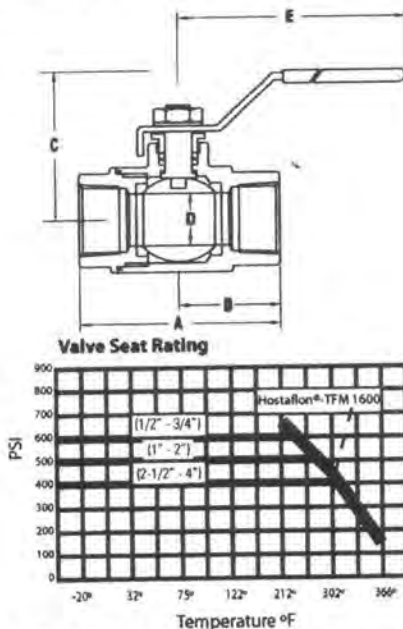

WARNING: T/S-100-NE valves are designed for temperatures up to 366°F, utilizing low pressure steam at 150 WSP MAXIMUM

Note: Information subject to change without notice.

Material Specifications

No.	Part Name	Materials
1	Body	Ecologically Washed Forged Brass
2	End Adapter	Ecologically Washed Forged Brass
3	Ball	Solid TEA Coated Brass Ball
4	Seat (2)	Hostaflon®-TFM 1600
5	Stem	Extruded Brass
6	Stem Packing	Hostaflon®-TFM 1600*
7	Stem O-Rings, (2)	Viton®
8	Gland Follower	Extruded Brass
9	Lever Handle	Dacromet Coated Steel
10	Handle Nut	Dacromet Coated Steel

Viton is a registered trademark of DuPont Company
Hostaflon is a registered trademark of Hoechst AG Frankfurt

Pressure Rating

1/4" - 3/4"	600 lbs. W.O.G. Non Shock
1" - 2"	500 lbs. W.O.G. Non Shock
2-1/2" - 4"	400 lbs. W.O.G. Non Shock
All Sizes:	150 WSP

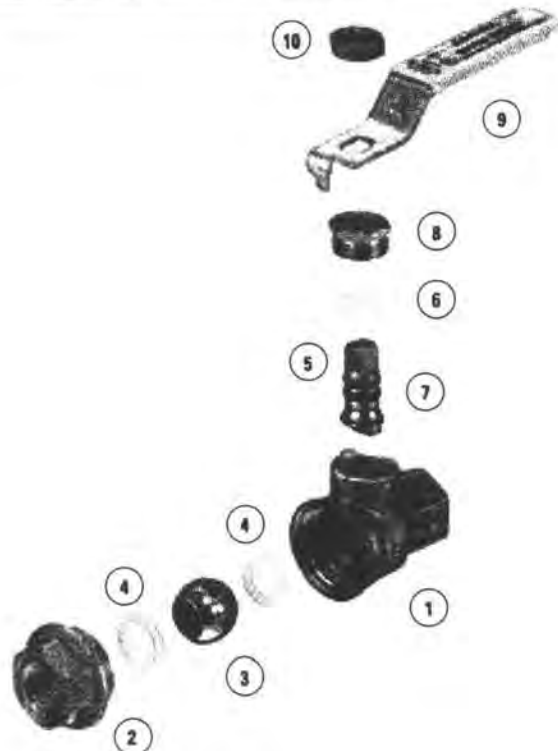

ADDENDUM ACKNOWLEDGEMENT FORM
SOLICITATION NO.: ARFQ DNR20*32

Instructions: Please acknowledge receipt of all addenda issued with this solicitation by completing this addendum acknowledgment form. Check the box next to each addendum received and sign below. Failure to acknowledge addenda may result in bid disqualification. Acknowledgment: I hereby acknowledge receipt of the following addenda and have made the necessary revisions to my proposal, plans and/or specification, etc.

Addendum Numbers Received:

(Check the box next to each addendum received)

- | | | | |
|-------------------------------------|----------------|--------------------------|-----------------|
| <input checked="" type="checkbox"/> | Addendum No. 1 | <input type="checkbox"/> | Addendum No. 6 |
| <input checked="" type="checkbox"/> | Addendum No. 2 | <input type="checkbox"/> | Addendum No. 7 |
| <input type="checkbox"/> | Addendum No. 3 | <input type="checkbox"/> | Addendum No. 8 |
| <input type="checkbox"/> | Addendum No. 4 | <input type="checkbox"/> | Addendum No. 9 |
| <input type="checkbox"/> | Addendum No. 5 | <input type="checkbox"/> | Addendum No. 10 |

I understand that failure to confirm the receipt of addenda may be cause for rejection of this bid. I further understand that any verbal representation made or assumed to be made during any oral discussion held between Vendor's representatives and any state personnel is not binding. Only the information issued in writing and added to the specifications by an official addendum is binding.

Stuck Enterprises

Company

JoJo Lambiotte
Authorized Signature

3-9-20

Date

NOTE: This addendum acknowledgement should be submitted with the bid to expedite document processing.

WEST VIRGINIA STATE TAX DEPARTMENT

MOTOR FUEL EXCISE TAX LICENSE

Effective: February 3, 2015

In accordance with West Virginia State Code §11-14C

STUCK ENTERPRISES, INC.

Is hereby licensed as:

License Type(s)	License Number(s)
<i>Importer</i>	<i>1600-4340</i>
<i>Exporter</i>	<i>1600-4338</i>
<i>Distributor</i>	<i>1600-4335</i>

This license is non-transferable and shall remain in effect until surrendered, canceled or revoked.



Timothy J. Wells, Tax Unit Supervisor
Fuel Tax Administration
Tax Account Administration

WEST VIRGINIA STATE TAX DEPARTMENT

MOTOR FUEL EXCISE TAX LICENSE

Issued: May 1, 2019

In accordance with West Virginia State Code §11-14C

**STUCK ENTERPRISES, INC.
DBA OAKLAND OIL & PROPANE**

Is hereby licensed as:

<u>License Type(s)</u>	<u>License Number(s)</u>	<u>Effective Date(s)</u>
<i>Motor Fuel Transporter</i>	<i>2376-1148</i>	<i>05/01/2019</i>

This license is non-transferable and shall remain in effect until surrendered, canceled or revoked.

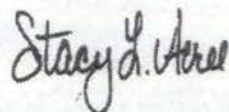

Stacy L. Acree, Assistant Director
Fuel Tax Administration Unit
Tax Account Administration Division

Request for Taxpayer Identification Number and Certification

Give Form to the requester. Do not send to the IRS.

▶ Go to www.irs.gov/FormW9 for instructions and the latest information.

1 Name (as shown on your income tax return). Name is required on this line; do not leave this line blank.
STUCK ENTERPRISES, INC.

2 Business name/disregarded entity name, if different from above

3 Check appropriate box for federal tax classification of the person whose name is entered on line 1. Check only **one** of the following seven boxes.

Individual/sole proprietor or single-member LLC

C Corporation

S Corporation

Partnership

Trust/estate

Limited liability company. Enter the tax classification (C=C corporation, S=S corporation, P=Partnership) ▶ _____

Note: Check the appropriate box in the line above for the tax classification of the single-member owner. Do not check LLC if the LLC is classified as a single-member LLC that is disregarded from the owner unless the owner of the LLC is another LLC that is **not** disregarded from the owner for U.S. federal tax purposes. Otherwise, a single-member LLC that is disregarded from the owner should check the appropriate box for the tax classification of its owner.

Other (see instructions) ▶ _____

4 Exemptions (codes apply only to certain entities, not individuals; see instructions on page 3):

Exempt payee code (if any) _____

Exemption from FATCA reporting code (if any) _____

(Applies to accounts maintained outside the U.S.)

5 Address (number, street, and apt. or suite no.) See instructions.
1115 EAST HIGH STREET

6 City, state, and ZIP code
WAYNESBURG, PA 15370

7 List account number(s) here (optional)

Requester's name and address (optional)

Part I Taxpayer Identification Number (TIN)

Enter your TIN in the appropriate box. The TIN provided must match the name given on line 1 to avoid backup withholding. For individuals, this is generally your social security number (SSN). However, for a resident alien, sole proprietor, or disregarded entity, see the instructions for Part I, later. For other entities, it is your employer identification number (EIN). If you do not have a number, see *How to get a TIN*, later.

Note: If the account is in more than one name, see the instructions for line 1. Also see *What Name and Number To Give the Requester* for guidelines on whose number to enter.

Social security number									
or									
Employer identification number									
2	5	-	1	3	0	5	6	2	5

Part II Certification

Under penalties of perjury, I certify that:

- The number shown on this form is my correct taxpayer identification number (or I am waiting for a number to be issued to me); and
- I am not subject to backup withholding because: (a) I am exempt from backup withholding, or (b) I have not been notified by the Internal Revenue Service (IRS) that I am subject to backup withholding as a result of a failure to report all interest or dividends, or (c) the IRS has notified me that I am no longer subject to backup withholding; and
- I am a U.S. citizen or other U.S. person (defined below); and
- The FATCA code(s) entered on this form (if any) indicating that I am exempt from FATCA reporting is correct.

Certification instructions. You must cross out item 2 above if you have been notified by the IRS that you are currently subject to backup withholding because you have failed to report all interest and dividends on your tax return. For real estate transactions, item 2 does not apply. For mortgage interest paid, acquisition or abandonment of secured property, cancellation of debt, contributions to an individual retirement arrangement (IRA), and generally, payments other than interest and dividends, you are not required to sign the certification, but you must provide your correct TIN. See the instructions for Part II, later.

Sign Here Signature of U.S. person ▶ Date ▶ 2/3/2020

General Instructions

Section references are to the Internal Revenue Code unless otherwise noted.

Future developments. For the latest information about developments related to Form W-9 and its instructions, such as legislation enacted after they were published, go to www.irs.gov/FormW9.

Purpose of Form

An individual or entity (Form W-9 requester) who is required to file an information return with the IRS must obtain your correct taxpayer identification number (TIN) which may be your social security number (SSN), individual taxpayer identification number (ITIN), adoption taxpayer identification number (ATIN), or employer identification number (EIN), to report on an information return the amount paid to you, or other amount reportable on an information return. Examples of information returns include, but are not limited to, the following.

- Form 1099-DIV (dividends, including those from stocks or mutual funds)
- Form 1099-MISC (various types of income, prizes, awards, or gross proceeds)
- Form 1099-B (stock or mutual fund sales and certain other transactions by brokers)
- Form 1099-S (proceeds from real estate transactions)
- Form 1099-K (merchant card and third party network transactions)
- Form 1098 (home mortgage interest), 1098-E (student loan interest), 1098-T (tuition)
- Form 1099-C (canceled debt)
- Form 1099-A (acquisition or abandonment of secured property)

Use Form W-9 only if you are a U.S. person (including a resident alien), to provide your correct TIN.

If you do not return Form W-9 to the requester with a TIN, you might be subject to backup withholding. See What is backup withholding, later.



CERTIFICATE OF LIABILITY INSURANCE

DATE (MM/DD/YYYY)
01/22/2020

THIS CERTIFICATE IS ISSUED AS A MATTER OF INFORMATION ONLY AND CONFERS NO RIGHTS UPON THE CERTIFICATE HOLDER. THIS CERTIFICATE DOES NOT AFFIRMATIVELY OR NEGATIVELY AMEND, EXTEND OR ALTER THE COVERAGE AFFORDED BY THE POLICIES BELOW. THIS CERTIFICATE OF INSURANCE DOES NOT CONSTITUTE A CONTRACT BETWEEN THE ISSUING INSURER(S), AUTHORIZED REPRESENTATIVE OR PRODUCER, AND THE CERTIFICATE HOLDER.

IMPORTANT: If the certificate holder is an ADDITIONAL INSURED, the policy(ies) must have ADDITIONAL INSURED provisions or be endorsed. If SUBROGATION IS WAIVED, subject to the terms and conditions of the policy, certain policies may require an endorsement. A statement on this certificate does not confer rights to the certificate holder in lieu of such endorsement(s).

PRODUCER FEDERATED MUTUAL INSURANCE COMPANY HOME OFFICE: P.O. BOX 328 OWATONNA, MN 55060	CONTACT NAME: CLIENT CONTACT CENTER PHONE (A/C, No, Ext): 888-333-4949 FAX (A/C, No): 507-446-4664 E-MAIL ADDRESS: CLIENTCONTACTCENTER@FEDINS.COM													
	<table border="1"> <thead> <tr> <th>INSURER(S) AFFORDING COVERAGE</th> <th>NAIC #</th> </tr> </thead> <tbody> <tr> <td>INSURER A: FEDERATED MUTUAL INSURANCE COMPANY</td> <td>13935</td> </tr> <tr> <td>INSURER B:</td> <td></td> </tr> <tr> <td>INSURER C:</td> <td></td> </tr> <tr> <td>INSURER D:</td> <td></td> </tr> <tr> <td>INSURER E:</td> <td></td> </tr> <tr> <td>INSURER F:</td> <td></td> </tr> </tbody> </table>	INSURER(S) AFFORDING COVERAGE	NAIC #	INSURER A: FEDERATED MUTUAL INSURANCE COMPANY	13935	INSURER B:		INSURER C:		INSURER D:		INSURER E:		INSURER F:
INSURER(S) AFFORDING COVERAGE	NAIC #													
INSURER A: FEDERATED MUTUAL INSURANCE COMPANY	13935													
INSURER B:														
INSURER C:														
INSURER D:														
INSURER E:														
INSURER F:														
INSURED 040-233-9 STUCK ENTERPRISES, INC., JACOBS PETROLEUM PRODUCTS, LLC 1115 E HIGH ST WAYNESBURG, PA 15370-1785														

COVERAGES CERTIFICATE NUMBER: 155 REVISION NUMBER: 0

THIS IS TO CERTIFY THAT THE POLICIES OF INSURANCE LISTED BELOW HAVE BEEN ISSUED TO THE INSURED NAMED ABOVE FOR THE POLICY PERIOD INDICATED. NOTWITHSTANDING ANY REQUIREMENT, TERM OR CONDITION OF ANY CONTRACT OR OTHER DOCUMENT WITH RESPECT TO WHICH THIS CERTIFICATE MAY BE ISSUED OR MAY PERTAIN, THE INSURANCE AFFORDED BY THE POLICIES DESCRIBED HEREIN IS SUBJECT TO ALL THE TERMS, EXCLUSIONS AND CONDITIONS OF SUCH POLICIES. LIMITS SHOWN MAY HAVE BEEN REDUCED BY PAID CLAIMS.

INSR LTR	TYPE OF INSURANCE	ADDL INSR	SUBR WVD	POLICY NUMBER	POLICY EFF (MM/DD/YYYY)	POLICY EXP (MM/DD/YYYY)	LIMITS	
A	<input checked="" type="checkbox"/> COMMERCIAL GENERAL LIABILITY <input type="checkbox"/> CLAIMS-MADE <input checked="" type="checkbox"/> OCCUR GEN'L AGGREGATE LIMIT APPLIES PER: <input checked="" type="checkbox"/> POLICY <input type="checkbox"/> PRO-JECT <input type="checkbox"/> LOC OTHER:		Y	N	6098614	04/01/2019	04/01/2020	EACH OCCURRENCE \$1,000,000 DAMAGE TO RENTED PREMISES (Ea occurrence) \$100,000 MED EXP (Any one person) EXCLUDED PERSONAL & ADV INJURY \$1,000,000 GENERAL AGGREGATE \$2,000,000 PRODUCTS - COMP/OP AGG \$2,000,000
A	AUTOMOBILE LIABILITY <input checked="" type="checkbox"/> ANY AUTO <input type="checkbox"/> OWNED AUTOS ONLY <input type="checkbox"/> SCHEDULED AUTOS NON-OWNED AUTOS ONLY <input type="checkbox"/> HIRED AUTOS ONLY		Y	N	6098614	04/01/2019	04/01/2020	COMBINED SINGLE LIMIT (Ea accident) \$1,000,000 BODILY INJURY (Per person) BODILY INJURY (Per accident) PROPERTY DAMAGE (Per accident)
A	<input checked="" type="checkbox"/> UMBRELLA LIAB <input checked="" type="checkbox"/> OCCUR <input type="checkbox"/> EXCESS LIAB <input type="checkbox"/> CLAIMS-MADE DED RETENTION		N	N	6098616	04/01/2019	04/01/2020	EACH OCCURRENCE \$4,000,000 AGGREGATE \$4,000,000
A	WORKERS COMPENSATION AND EMPLOYERS' LIABILITY ANY PROPRIETOR/PARTNER/EXECUTIVE OFFICER/MEMBER EXCLUDED? (Mandatory in NH) If yes, describe under DESCRIPTION OF OPERATIONS below	Y/N	N/A	N	6098615	04/01/2019	04/01/2020	<input checked="" type="checkbox"/> PER STATUTE <input type="checkbox"/> OTH-ER E.L. EACH ACCIDENT \$1,000,000 E.L. DISEASE - EA EMPLOYEE \$1,000,000 E.L. DISEASE - POLICY LIMIT \$1,000,000

DESCRIPTION OF OPERATIONS / LOCATIONS / VEHICLES (ACORD 101, Additional Remarks Schedule, may be attached if more space is required)

THE CERTIFICATE HOLDER IS AN ADDITIONAL INSURED ON GENERAL LIABILITY SUBJECT TO THE CONDITIONS OF THE ADDITIONAL INSURED - DESIGNATED PERSON OR ORGANIZATION ENDORSEMENT.
 THE CERTIFICATE HOLDER IS AN ADDITIONAL INSURED ON BUSINESS AUTO LIABILITY.
 FOR REASONS OTHER THAN NON-PAYMENT OF PREMIUM, 30 DAYS NOTICE WILL BE PROVIDED TO THE CERTIFICATE HOLDER IN THE EVENT THAT THE ISSUING COMPANY CANCELS THE POLICY BEFORE THE EXPIRATION DATE OF THE POLICY.

CERTIFICATE HOLDER

040-233-9 155 0
 STATE OF WV
 1900 KANAWHA BLVD E RM 5
 CHARLESTON, WV 25305-0001

CANCELLATION

SHOULD ANY OF THE ABOVE DESCRIBED POLICIES BE CANCELLED BEFORE THE EXPIRATION DATE THEREOF, NOTICE WILL BE DELIVERED IN ACCORDANCE WITH THE POLICY PROVISIONS.

AUTHORIZED REPRESENTATIVE

Michael G Ken

© 1988-2015 ACORD CORPORATION. All rights reserved.

FEDERATED INSURANCE COMPANIES

THIS ENDORSEMENT CHANGES THE POLICY. PLEASE READ IT CAREFULLY.

ADDITIONAL INSURED ENDORSEMENT

This endorsement modifies insurance provided under the following:

BUSINESS AUTO COVERAGE PART

INSURED:

STUCK ENTERPRISES, INC.
1115 E HIGH ST
WAYNESBURG PA 15370

1. WHO IS AN INSURED for "bodily injury" and "property damage" liability is amended to include the Additional Insured specified below but only with respect to liability arising out of your operations or premises owned by or rented to you.
2. The insurance does not apply to "bodily injury" or "property damage" liability arising out of the sole negligence of the Additional Insured named below.
3. We agree to notify the Additional Insured named below at the address stated below of any cancellation of, or material change to, this policy.

Relationship of the Additional Insured to the Insured:

ANY COVERAGE PROVIDED BY THIS ENDORSEMENT APPLIES
ONLY TO DELIVERY OF FUEL TO CERTIFICATE HOLDER
LOCATION(S).

Additional Insured Name and Address:

STATE OF WV
1900 KANAWHA BLVD E RM 5
CHARLESTON WV 25305

Includes copyrighted material of Insurance Services Office, Inc. with its permission.

THIS ENDORSEMENT CHANGES THE POLICY. PLEASE READ IT CAREFULLY.

**ADDITIONAL INSURED - DESIGNATED
PERSON OR ORGANIZATION**

This endorsement modifies insurance provided under the following:

COMMERCIAL GENERAL LIABILITY COVERAGE PART

SCHEDULE

Name Of Additional Person(s) Or Organization(s):	DESCRIPTION OF INTEREST IF APPLICABLE:
STATE OF WV 1900 KANAWHA BLVD E RM 5 CHARLESTON WV 25305	ANY COVERAGE PROVIDED BY THIS ENDORSEMENT APPLIES ONLY TO DELIVERY OF FUEL TO CERTIFICATE HOLDER LOCATION(S).
Information required to complete this Schedule, if not shown above, will be shown in the Declarations.	

A. Section II - Who Is An Insured is amended to include as an additional insured the person(s) or organization(s) shown in the Schedule, but only with respect to liability for "bodily injury", "property damage" or "personal and advertising injury" caused, in whole or in part, by your acts or omissions or the acts or omissions of those acting on your behalf:

1. In the performance of your ongoing operations; or
2. In connection with your premises owned by or rented to you.

However:

1. The insurance afforded to such additional insured only applies to the extent permitted by law; and
2. If coverage provided to the additional insured is required by a contract or agreement, the insurance afforded to such additional insured will not be broader than that which you are required by the contract or agreement to provide for such additional insured.

STUCK ENTERPRISES, INC.
1115 E HIGH ST
WAYNESBURG PA 15370

B. With respect to the insurance afforded to these additional insureds, the following is added to **Section III - Limits Of Insurance:**

If coverage provided to the additional insured is required by a contract or agreement, the most we will pay on behalf of the additional insured is the amount of insurance:

1. Required by the contract or agreement; or
2. Available under the applicable Limits of Insurance shown in the Declarations;

whichever is less.

This endorsement shall not increase the applicable Limits of Insurance shown in the Declarations.